

Robin DL7F Wash

Photometric Diagrams

Fresnel lens - Min. zoom

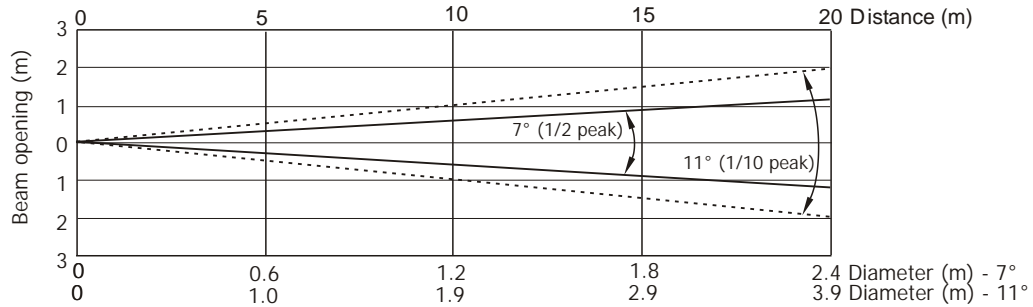

Output Mode: CRI (70)

| Distance (m) | 5 | 8 | 10 | 12 | 14 | 16 | 18 | 20 | |
|--------------|------------|----------|----------|----------|----------|----------|--------|--------|---------------------------------------|
| White 2700K | 7000/650 | 2734/254 | 1750/162 | 1245/113 | 893/83 | 684/64 | 540/50 | 438/41 | Intensity (center) Lux/Footcandles |
| White 3200K | 8050/748 | 3145/292 | 2012/187 | 1398/130 | 1027/95 | 786/73 | 621/58 | 503/47 | |
| White 4200K | 9620/894 | 3757/350 | 2405/223 | 1670/155 | 1227/114 | 940/87 | 742/69 | 600/56 | |
| White 5600K | 10800/1003 | 4218/392 | 2700/251 | 1875/174 | 1377/128 | 1055/98 | 833/77 | 675/63 | |
| White 6600K | 11220/1042 | 4382/407 | 2805/261 | 1948/181 | 1430/133 | 1095/102 | 865/80 | 700/65 | |
| White 8000K | 11820/1098 | 4620/429 | 2955/275 | 2050/192 | 1507/140 | 1154/107 | 912/85 | 740/69 | |

Illuminance distribution

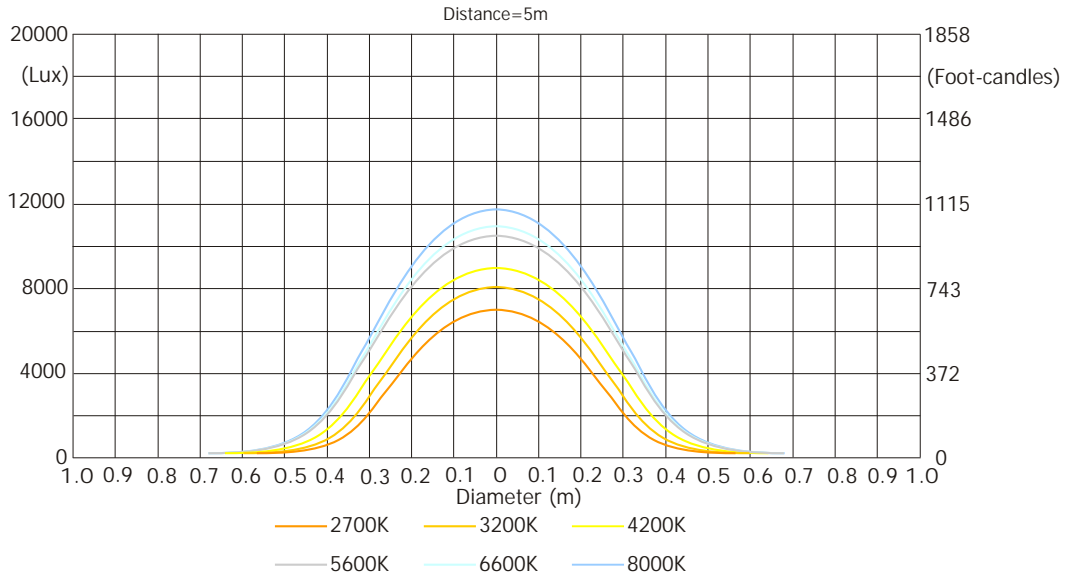

Fixture settings:

DMX Mode: 3 (R+G+B+A+C+CB+LG=full)
 Colour calibration mode: On
 Colour mixing mode: RGB
 Output mode: CRI
 Output Uniformity: On
 Output Consistency: 50°C
 CRI Selection: 70
 Theatre mode: Off

Robin DL7F Wash

Photometric Diagrams

PC lens - Min. zoom

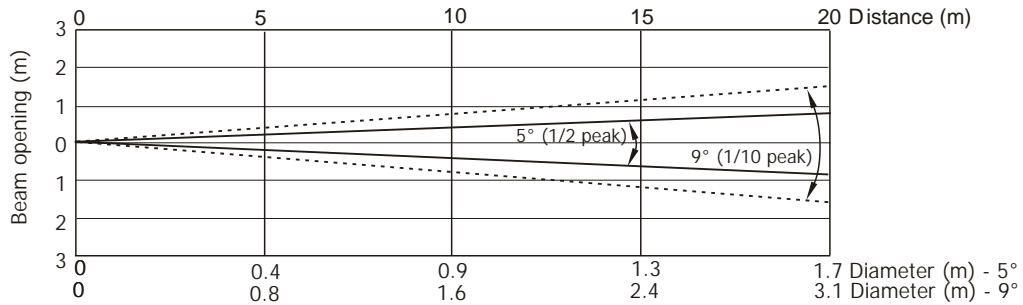

Output Mode: CRI (70)

| Distance (m) | 5 | 8 | 10 | 12 | 14 | 16 | 18 | 20 | |
|--------------|------------|----------|----------|----------|----------|----------|----------|----------|---------------------------------------|
| White 2700K | 10750/999 | 4200/390 | 2687/250 | 1866/173 | 1371/127 | 1050/98 | 830/77 | 672/62 | Intensity (center) Lux/Footcandles |
| White 3200K | 12130/1127 | 4738/440 | 3032/282 | 2106/196 | 1547/144 | 1185/110 | 936/87 | 758/70 | |
| White 4200K | 14730/1369 | 5754/535 | 3683/342 | 2557/238 | 1878/175 | 1440/134 | 1137/106 | 920/86 | |
| White 5600K | 16580/1540 | 6477/602 | 4145/385 | 2879/267 | 2115/197 | 1619/150 | 1279/119 | 1036/96 | |
| White 6600K | 17270/1604 | 6746/627 | 4318/401 | 2998/279 | 2202/205 | 1686/157 | 1332/124 | 1079/100 | |
| White 8000K | 18280/1698 | 7140/663 | 4570/425 | 3174/295 | 2332/217 | 1785/166 | 1410/131 | 1142/106 | |

Illuminance distribution

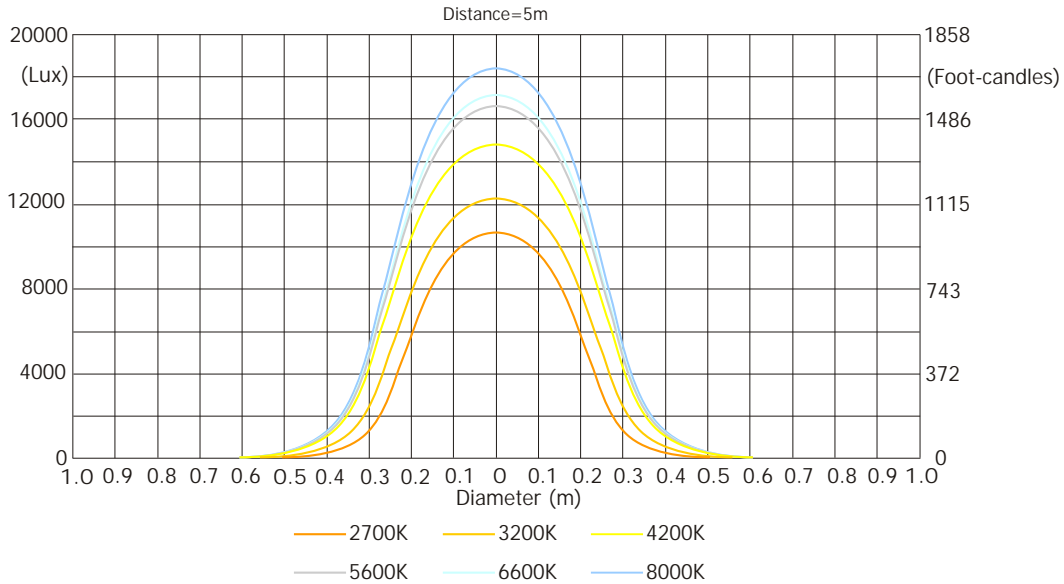

Fixture settings:

DMX Mode: 3 (R+G+B+A+C+CB+LG=full)
 Colour calibration mode: On
 Colour mixing mode: RGB
 Output mode: CRI
 Output Uniformity: On
 Output Consistency: 50°C
 CRI Selection: 70
 Theatre mode: Off

Robin DL7F Wash

Photometric Diagrams

Fresnel lens - Max. zoom

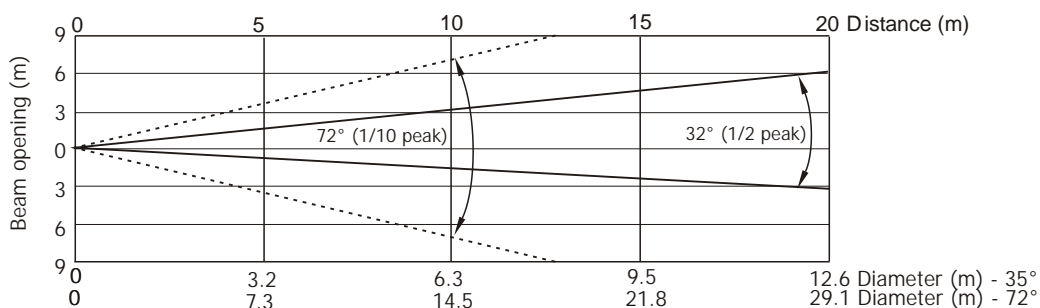

Output Mode: CRI (70)

| Distance (m) | 5 | 8 | 10 | 12 | 14 | 16 | 18 | 20 | |
|--------------|--------|---------|--------|------|------|--------|--------|--------|---------------------------------------|
| White 2700K | 305/28 | 120/118 | 76/7 | 53/5 | 39/4 | 30/3 | 24/2.2 | 19/1.8 | Intensity (center) Lux/footcandles |
| White 3200K | 344/32 | 134/13 | 86/8 | 60/6 | 44/4 | 34/3 | 27/2.5 | 22/2 | |
| White 4200K | 419/39 | 164/15 | 105/10 | 73/7 | 54/5 | 40/4 | 32/3 | 26/2.4 | |
| White 5600K | 471/44 | 184/17 | 118/11 | 82/8 | 60/6 | 46/4 | 36/3.4 | 29/2.7 | |
| White 6600K | 490/46 | 191/18 | 123/12 | 85/8 | 63/6 | 48/4.4 | 38/3.5 | 30/2.8 | |
| White 8000K | 525/49 | 205/19 | 131/12 | 91/9 | 67/6 | 51/5 | 40/3.8 | 33/3 | |

Illuminance distribution

Distance=5m

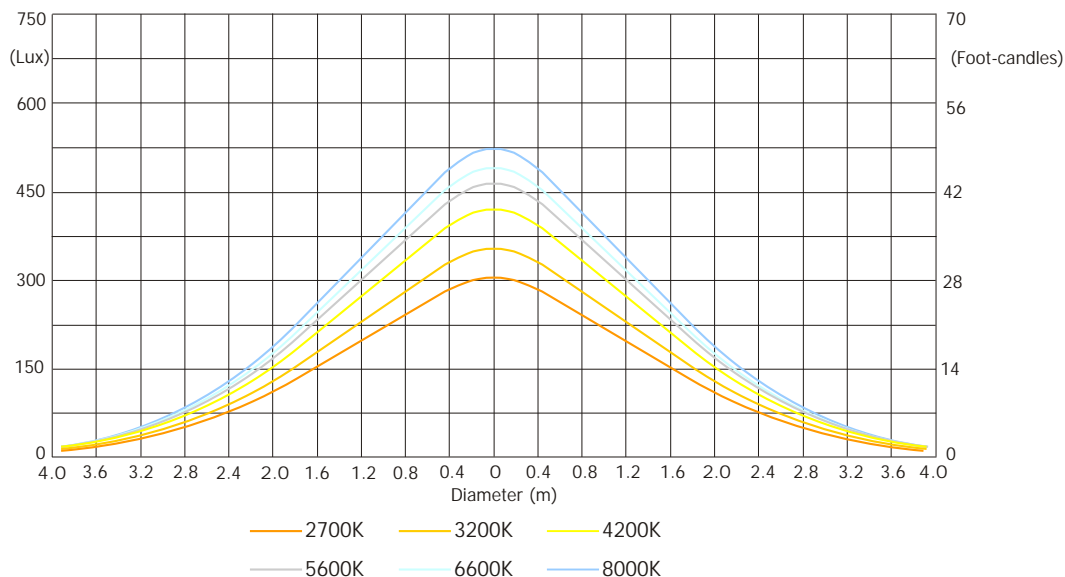

Fixture settings:

DMX Mode: 3 (R+G+B+A+C+CB+LG=full)
 Colour calibration mode: On
 Colour mixing mode: RGB
 Output mode: CRI
 Output Uniformity: On
 Output Consistency: 50°C
 CRI Selection: 70
 Theatre mode: Off

Robin DL7F Wash

Photometric Diagrams

PC lens - Max. zoom

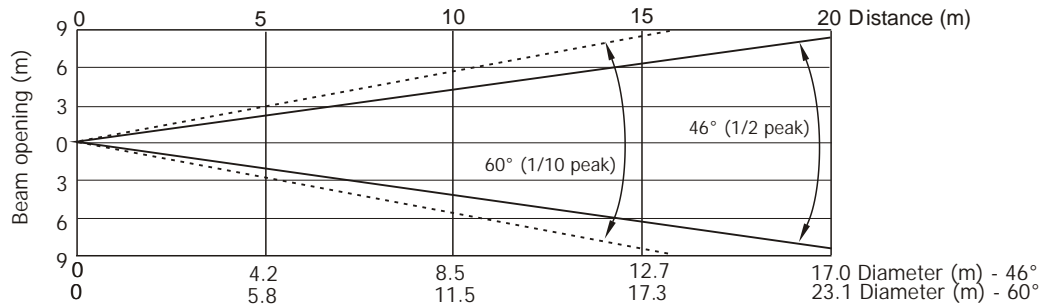

Output Mode: CRI (70)

| Distance (m) | 5 | 8 | 10 | 12 | 14 | 16 | 18 | 20 | |
|--------------|--------|--------|--------|--------|--------|--------|--------|--------|---------------------------------------|
| White 2700K | 253/24 | 99/9 | 63/6 | 44/4 | 32/3 | 25/2.3 | 20/1.8 | 16/1.5 | Intensity (center) Lux/Footcandles |
| White 3200K | 288/27 | 113/11 | 72/7 | 50/4.7 | 37/3.4 | 28/2.6 | 22/2.1 | 18/1.7 | |
| White 4200K | 350/33 | 137/13 | 88/8 | 61/6 | 45/4 | 34/3.2 | 27/2.5 | 22/2 | |
| White 5600K | 394/37 | 154/14 | 99/9 | 68/6 | 50/4.7 | 39/3.6 | 30/2.8 | 25/2.3 | |
| White 6600K | 403/37 | 157/15 | 100/9 | 70/7 | 51/5 | 39/3.6 | 30/2.8 | 25/2.3 | |
| White 8000K | 430/40 | 168/16 | 108/10 | 75/7 | 55/5 | 42/4 | 33/3 | 27/2.5 | |

Illuminance distribution

Distance=5m

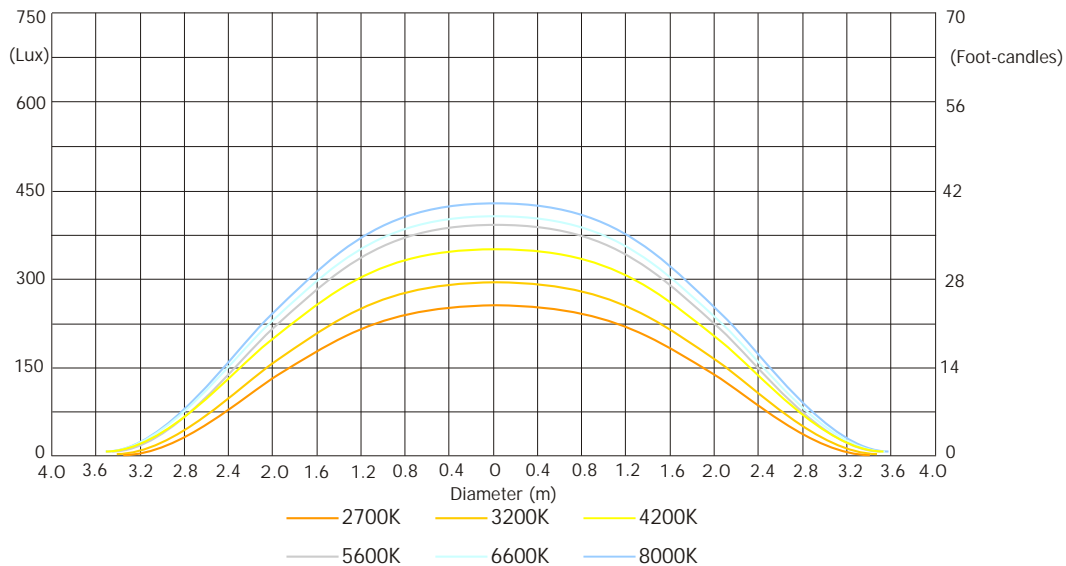

Fixture settings:

DMX Mode: 3 (R+G+B+A+C+CB+LG=full)
 Colour calibration mode: On
 Colour mixing mode: RGB
 Output mode: CRI
 Output Uniformity: On
 Output Consistency: 50°C
 CRI Selection: 70
 Theatre mode: Off

Robin DL7F Wash

Photometric Diagrams

Fresnel lens - Min. zoom

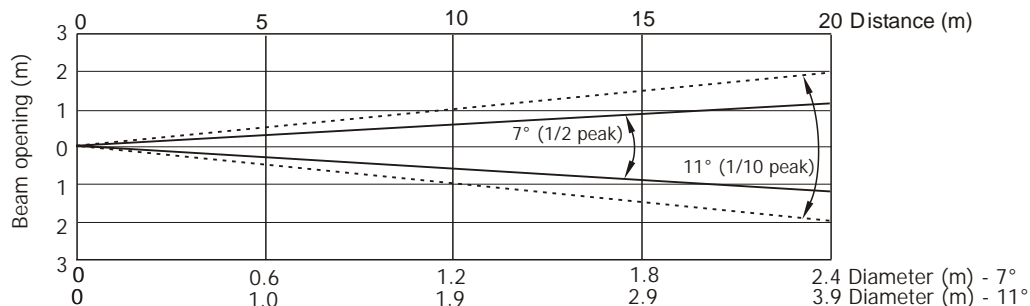

Output Mode: CRI (80)

| Distance (m) | 5 | 8 | 10 | 12 | 14 | 16 | 18 | 20 | |
|--------------|-----------|----------|----------|----------|----------|---------|--------|--------|---------------------------------------|
| White 2700K | 5940/552 | 2320/216 | 1485/138 | 1030/96 | 758/70 | 580/54 | 458/43 | 371/35 | Intensity (center) Lux/Footcandles |
| White 3200K | 6790/631 | 2652/246 | 1698/158 | 1180/110 | 866/81 | 663/62 | 524/49 | 424/39 | |
| White 4200K | 8215/763 | 3210/298 | 2054/191 | 1426/133 | 1048/97 | 802/74 | 634/59 | 513/48 | |
| White 5600K | 9400/873 | 3672/341 | 2350/218 | 1632/152 | 1199/111 | 918/85 | 725/67 | 587/55 | |
| White 6600K | 9900/920 | 3867/360 | 2475/230 | 1718/160 | 1263/117 | 967/90 | 764/71 | 619/58 | |
| White 8000K | 10640/989 | 4156/386 | 2660/247 | 1847/172 | 1357/126 | 1039/97 | 821/76 | 665/62 | |

Illuminance distribution

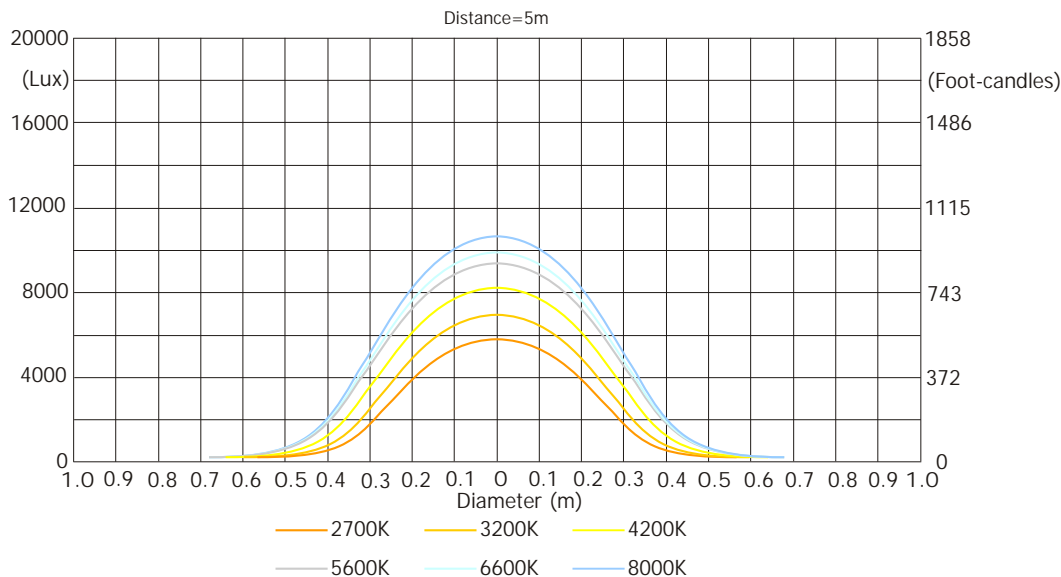

Fixture settings:

DMX Mode: 3 (R+G+B+A+C+CB+LG=full)
 Colour calibration mode: On
 Colour mixing mode: RGB
 Output mode: CRI
 Output Uniformity: On
 Output Consistency: 50°C
 CRI Selection: 80
 Theatre mode: Off

Robin DL7F Wash

Photometric Diagrams

PC lens - Min. zoom

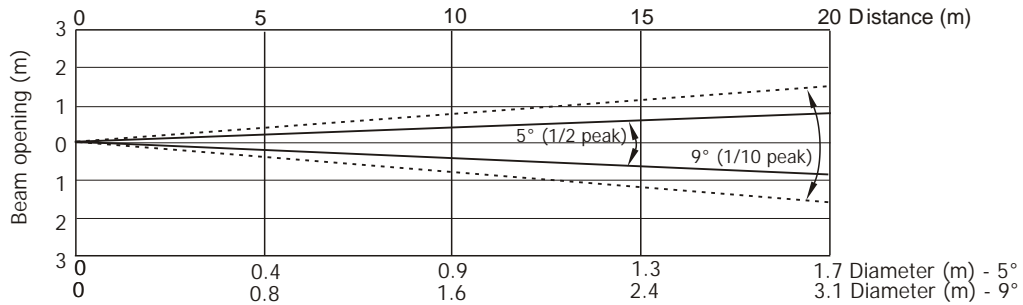

Output Mode: CRI (80)

| Distance (m) | 5 | 8 | 10 | 12 | 14 | 16 | 18 | 20 | |
|--------------|------------|----------|----------|----------|----------|----------|----------|---------|---------------------------------------|
| White 2700K | 9330/867 | 3645/339 | 2333/217 | 1620/151 | 1190/111 | 911/85 | 720/67 | 583/54 | Intensity (center) Lux/Footcandles |
| White 3200K | 10700/994 | 4180/388 | 2675/249 | 1858/173 | 1365/127 | 1045/97 | 826/77 | 669/62 | |
| White 4200K | 12640/1174 | 4938/459 | 3160/294 | 2194/204 | 1612/150 | 1234/115 | 975/91 | 790/73 | |
| White 5600K | 14750/1370 | 5762/535 | 3688/343 | 2560/238 | 1881/175 | 1440/134 | 1138/106 | 922/86 | |
| White 6600K | 15510/1440 | 6059/563 | 3878/360 | 2693/250 | 1978/184 | 1515/141 | 1197/111 | 969/90 | |
| White 8000K | 16640/1546 | 4160/387 | 4160/387 | 2888/268 | 2122/197 | 1625/151 | 1284/119 | 1040/97 | |

Illuminance distribution

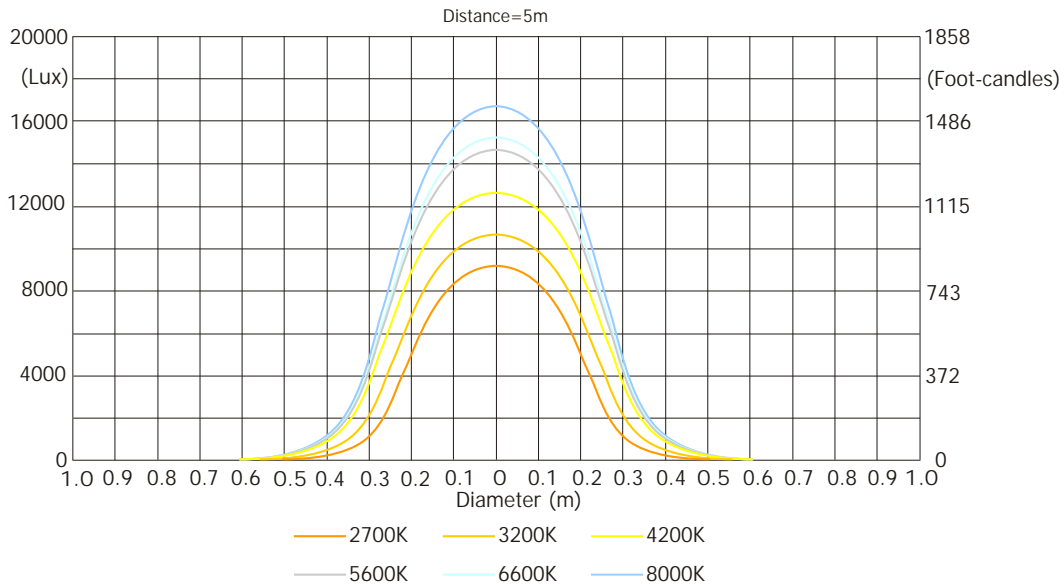

Fixture settings:

DMX Mode: 3 (R+G+B+A+C+CB+LG=full)
 Colour calibration mode: On
 Colour mixing mode: RGB
 Output mode: CRI
 Output Uniformity: On
 Output Consistency: 50°C
 CRI Selection: 80
 Theatre mode: Off

Robin DL7F Wash

Photometric Diagrams

Fresnel lens - Max. zoom

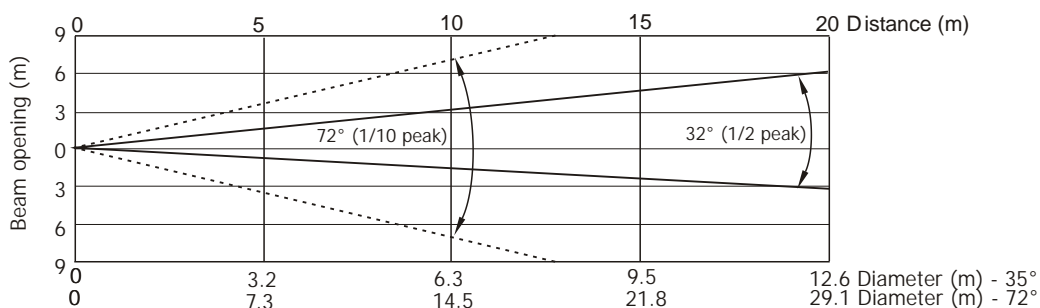

Output Mode: CRI (80)

| Distance (m) | 5 | 8 | 10 | 12 | 14 | 16 | 18 | 20 | |
|--------------|--------|--------|--------|------|------|--------|--------|--------|---------------------------------------|
| White 2700K | 262/24 | 102/10 | 66/6 | 46/4 | 33/3 | 26/2.4 | 20/2 | 16/1.5 | Intensity (center) Lux/Footcandles |
| White 3200K | 300/28 | 117/11 | 75/7 | 52/5 | 38/4 | 29/2.7 | 23/2.2 | 19/1.7 | |
| White 4200K | 365/34 | 143/13 | 91/9 | 63/6 | 47/4 | 36/3 | 28/2.6 | 23/2.1 | |
| White 5600K | 427/40 | 167/16 | 107/10 | 74/7 | 55/5 | 42/4 | 33/3.1 | 27/2.5 | |
| White 6600K | 446/42 | 174/16 | 112/10 | 77/7 | 57/5 | 44/4 | 34/3 | 28/2.6 | |
| White 8000K | 470/44 | 184/17 | 118/11 | 82/8 | 60/6 | 46/4 | 36/3.4 | 29/2.7 | |

Illuminance distribution

Distance=5m

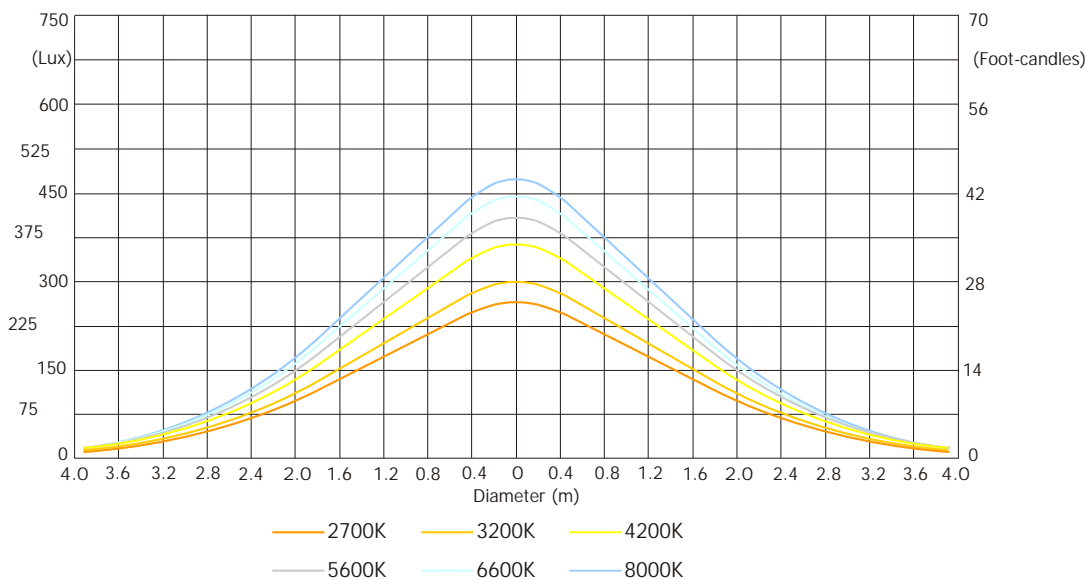

Fixture settings:

DMX Mode: 3 (R+G+B+A+C+CB+LG=full)
 Colour calibration mode: On
 Colour mixing mode: RGB
 Output mode: CRI
 Output Uniformity: On
 Output Consistency: 50°C
 CRI Selection: 80
 Theatre mode: Off

Robin DL7F Wash

Photometric Diagrams

PC lens - Max. zoom

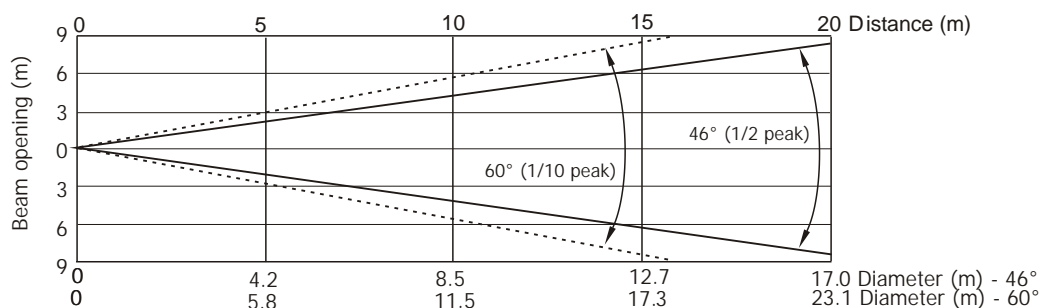

Output Mode: CRI (80)

| Distance (m) | 5 | 8 | 10 | 12 | 14 | 16 | 18 | 20 | |
|--------------|--------|--------|-------|------|--------|--------|--------|--------|---------------------------------------|
| White 2700K | 213/20 | 83/8 | 53/5 | 37/3 | 27/2.5 | 21/2 | 16/1.5 | 13/1.2 | Intensity (center) Lux/Footcandles |
| White 3200K | 245/23 | 96/9 | 61/6 | 42/4 | 32/3 | 24/2 | 19/1.8 | 15/1.4 | |
| White 4200K | 297/28 | 116/11 | 74/7 | 52/5 | 38/3.5 | 29/2.7 | 23/2 | 19/1.7 | |
| White 5600K | 345/32 | 135/13 | 86/8 | 60/6 | 44/4 | 34/3 | 27/2.5 | 22/2 | |
| White 6600K | 365/34 | 143/13 | 91/9 | 63/6 | 47/4 | 36/3.3 | 28/2.6 | 23/2.1 | |
| White 8000K | 400/37 | 156/15 | 100/9 | 69/7 | 51/5 | 39/3.6 | 31/3 | 25/2.3 | |

Illuminance distribution

Distance=5m

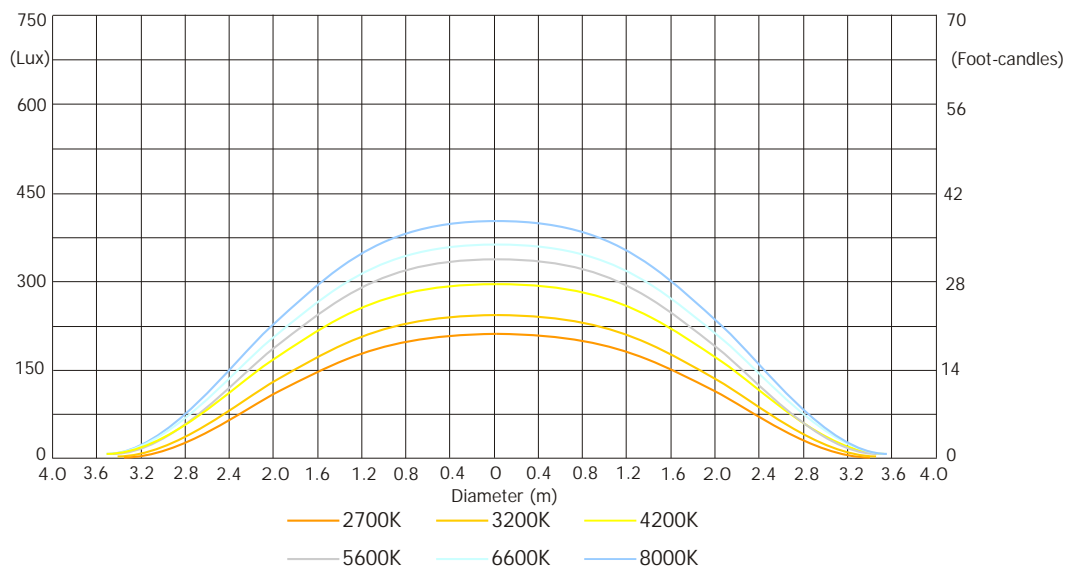

Fixture settings:

DMX Mode: 3 (R+G+B+A+C+CB+LG=full)
 Colour calibration mode: On
 Colour mixing mode: RGB
 Output mode: CRI
 Output Uniformity: On
 Output Consistency: 50°C
 CRI Selection: 80
 Theatre mode: Off

Robin DL7F Wash

Photometric Diagrams

Fresnel lens - Min. zoom

Total Output: 3120 lumens (at 8000K)

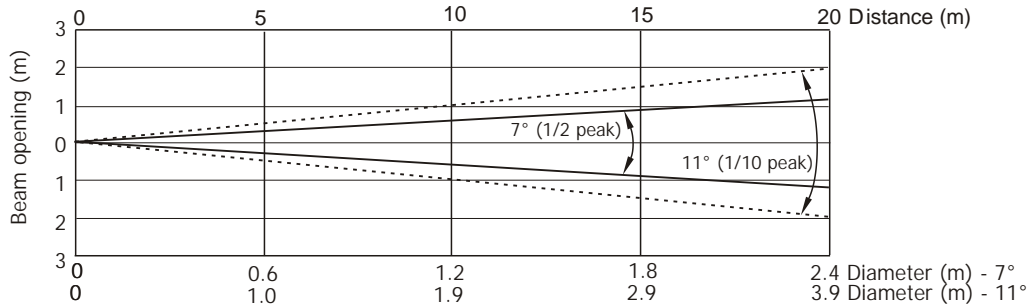

Output Mode: CRI (90+)

| Distance (m) | 5 | 8 | 10 | 12 | 14 | 16 | 18 | 20 | |
|--------------|----------|----------|----------|----------|----------|--------|--------|--------|---------------------------------------|
| White 2700K | 4850/450 | 1895/176 | 1213/113 | 842/78 | 619/58 | 475/44 | 374/35 | 300/28 | Intensity (center) Lux/Footcandles |
| White 3200K | 5560/516 | 2172/202 | 1390/129 | 965/90 | 709/66 | 543/50 | 430/40 | 348/32 | |
| White 4200K | 6870/638 | 2634/250 | 1718/160 | 1193/110 | 876/82 | 671/62 | 530/49 | 430/40 | |
| White 5600K | 8390/780 | 3277/305 | 2098/195 | 1456/135 | 1070/99 | 820/76 | 647/60 | 524/49 | |
| White 6600K | 8920/829 | 3484/324 | 2230/207 | 1549/144 | 1138/106 | 871/81 | 688/64 | 557/52 | |
| White 8000K | 9730/904 | 3800/353 | 2432/226 | 1690/157 | 1240/115 | 950/88 | 750/70 | 608/57 | |

Illuminance distribution

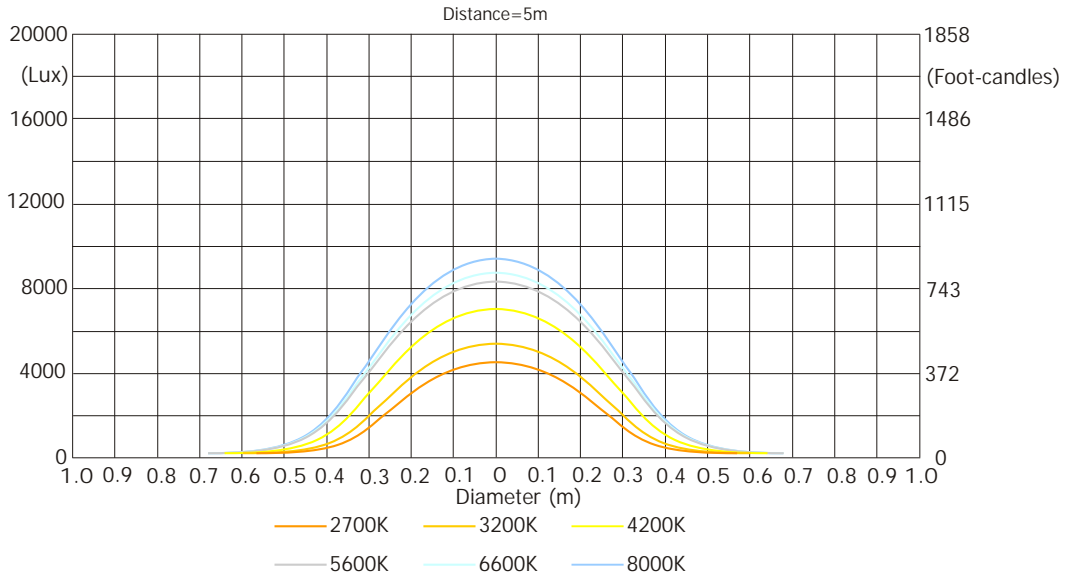

Fixture settings:

DMX Mode: 3 (R+G+B+A+C+CB+LG=full)
 Colour calibration mode: On
 Colour mixing mode: RGB
 Output mode: CRI
 Output Uniformity: On
 Output Consistency: 50°C
 CRI Selection: 90+
 Theatre mode: Off

Robin DL7F Wash

Photometric Diagrams

PC lens - Min. zoom

Total Output: 4780 lumens (at 8000K)

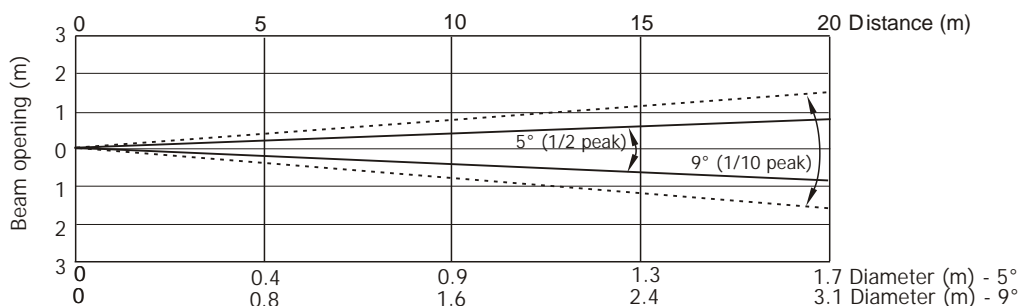

Output Mode: CRI (90+)

| Distance (m) | 5 | 8 | 10 | 12 | 14 | 16 | 18 | 20 | |
|--------------|------------|----------|----------|----------|----------|----------|----------|--------|---------------------------------------|
| White 2700K | 7400/688 | 2890/269 | 1850/172 | 1285/120 | 944/88 | 722/67 | 571/53 | 463/43 | Intensity (center) Lux/Footcandles |
| White 3200K | 8440/784 | 3297/306 | 2110/196 | 1465/136 | 1076/100 | 824/76 | 650/61 | 527/49 | |
| White 4200K | 10120/940 | 3953/367 | 2530/235 | 1756/163 | 1290/120 | 988/92 | 780/73 | 632/59 | |
| White 5600K | 12570/1168 | 4910/456 | 3143/292 | 2182/203 | 1603/150 | 1228/114 | 970/90 | 786/73 | |
| White 6600K | 13230/1230 | 5168/480 | 3308/307 | 2297/213 | 1688/157 | 1292/120 | 1020/95 | 827/77 | |
| White 8000K | 14410/1339 | 5630/523 | 3602/335 | 2500/232 | 1838/170 | 1407/130 | 1111/103 | 900/84 | |

Illuminance distribution

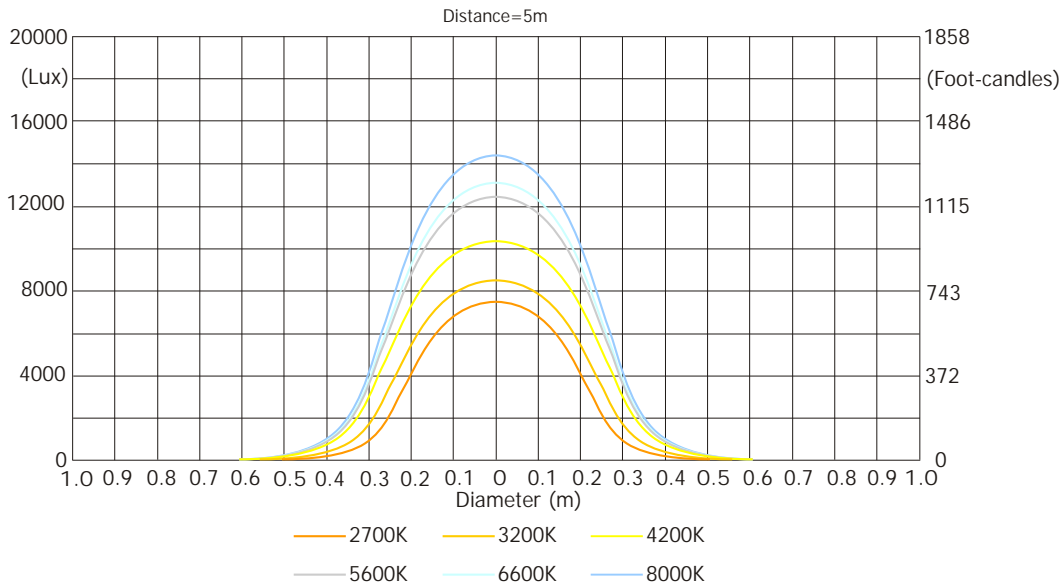

Fixture settings:

DMX Mode: 3 (R+G+B+A+C+CB+LG=full)
 Colour calibration mode: On
 Colour mixing mode: RGB
 Output mode: CRI
 Output Uniformity: On
 Output Consistency: 50°C
 CRI Selection: 90+
 Theatre mode: Off

Robin DL7F Wash

Photometric Diagrams

Fresnel lens - Max. zoom

Total Output: 6150 lumens (at 8000K)

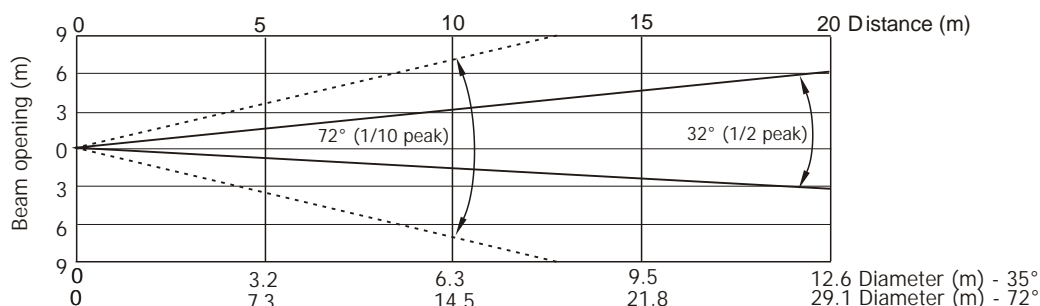

Output Mode: CRI (90+)

| Distance (m) | 5 | 8 | 10 | 12 | 14 | 16 | 18 | 20 | |
|--------------|--------|--------|--------|--------|--------|--------|--------|--------|---------------------------------------|
| White 2700K | 210/20 | 82/8 | 53/5 | 37/3.4 | 27/2.5 | 21/2 | 16/1.5 | 13/1.2 | Intensity (center) Lux/Footcandles |
| White 3200K | 242/23 | 95/9 | 60/6 | 42/4 | 30/3 | 24/2 | 19/1.7 | 15/1.4 | |
| White 4200K | 292/27 | 114/11 | 73/7 | 51/5 | 37/4 | 29/2.6 | 23/2 | 18/1.7 | |
| White 5600K | 356/33 | 139/13 | 90/8 | 62/6 | 45/4 | 35/3 | 28/2.6 | 22/2.1 | |
| White 6600K | 380/35 | 148/14 | 95/9 | 66/6 | 49/5 | 37/3.4 | 30/2.7 | 24/2.2 | |
| White 8000K | 415/39 | 162/15 | 104/10 | 72/7 | 53/5 | 41/4 | 32/3 | 25/2.4 | |

Illuminance distribution

Distance=5m

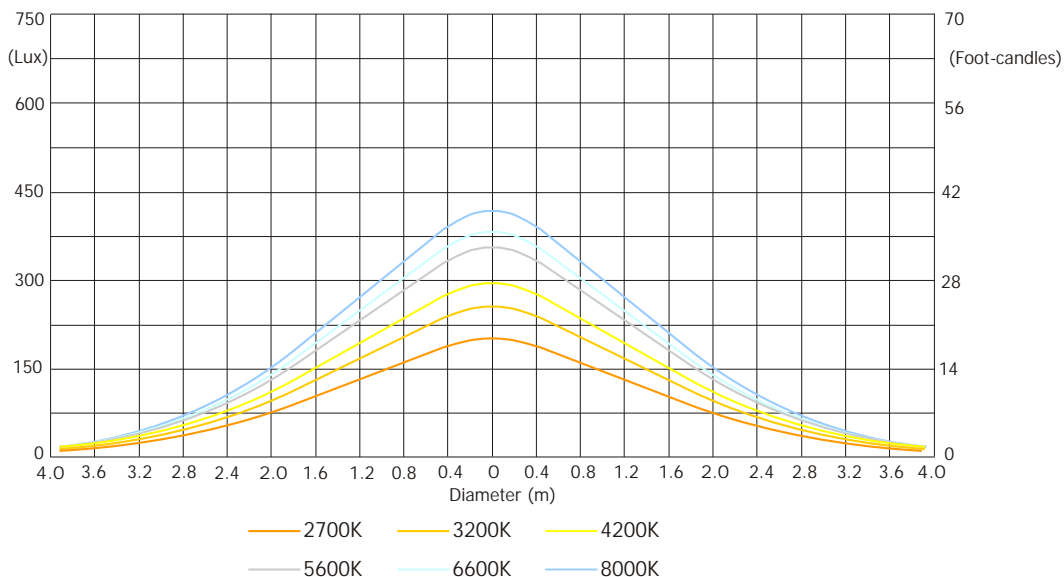

Fixture settings:

DMX Mode: 3 (R+G+B+A+C+CB+LG=full)
 Colour calibration mode: On
 Colour mixing mode: RGB
 Output mode: CRI
 Output Uniformity: On
 Output Consistency: 50°C
 CRI Selection: 90+
 Theatre mode: Off

Robin DL7F Wash

Photometric Diagrams

PC lens - Max. zoom

Total Output: 7200 lumens (at 8000K)

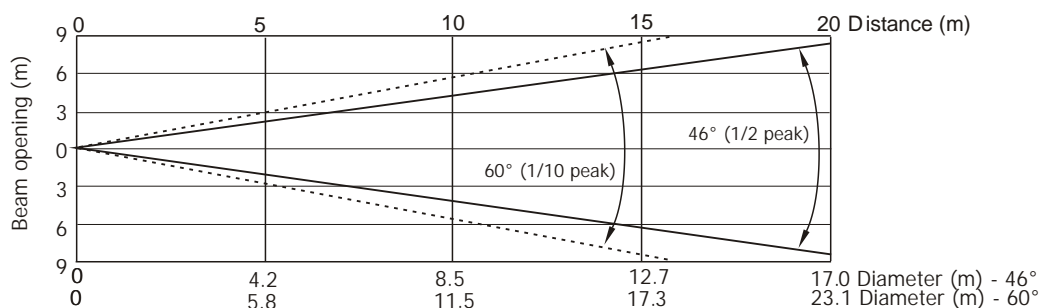

Output Mode: CRI (90+)

| Distance (m) | 5 | 8 | 10 | 12 | 14 | 16 | 18 | 20 | |
|--------------|--------|--------|------|------|--------|--------|--------|--------|---------------------------------------|
| White 2700K | 174/16 | 68/6 | 44/4 | 30/3 | 22/2 | 17/1.6 | 13/1.2 | 11/1 | Intensity (center) Lux/Footcandles |
| White 3200K | 201/19 | 79/7 | 50/5 | 35/3 | 26/2.4 | 20/1.8 | 16/1.4 | 13/1.2 | |
| White 4200K | 245/23 | 96/9 | 60/6 | 43/4 | 31/3 | 24/2 | 19/1.8 | 15/1.4 | |
| White 5600K | 305/28 | 119/11 | 76/7 | 53/5 | 39/4 | 30/2.8 | 24/2.2 | 19/1.8 | |
| White 6600K | 320/30 | 125/12 | 80/7 | 56/5 | 41/4 | 31/3 | 25/2.3 | 20/1.9 | |
| White 8000K | 350/33 | 137/13 | 87/8 | 60/6 | 45/4 | 34/3 | 27/2.5 | 22/2 | |

Illuminance distribution

Distance=5m

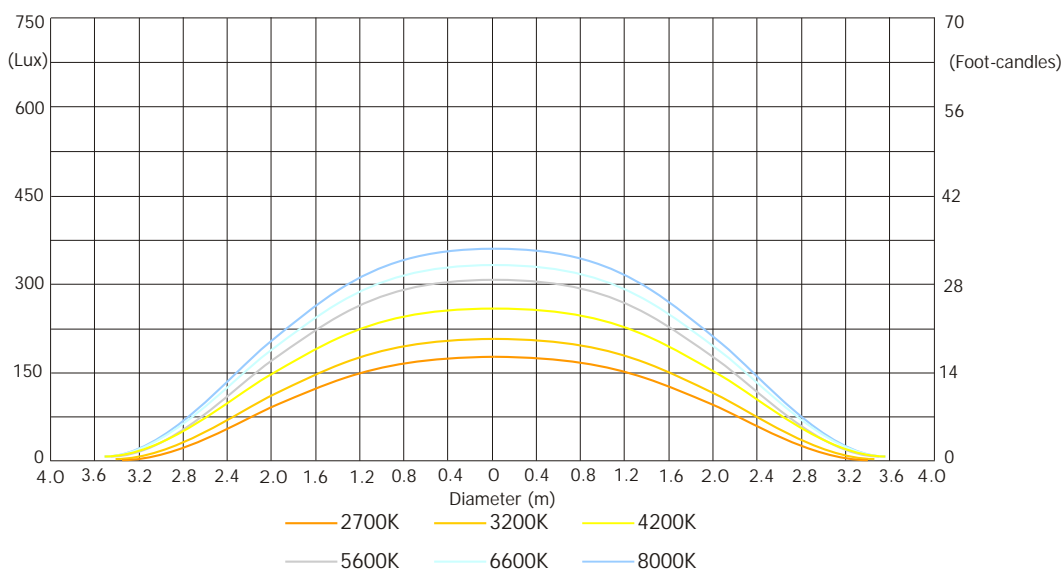

Fixture settings:

DMX Mode: 3 (R+G+B+A+C+CB+LG=full)
 Colour calibration mode: On
 Colour mixing mode: RGB
 Output mode: CRI
 Output Uniformity: On
 Output Consistency: 50°C
 CRI Selection: 90+
 Theatre mode: Off

Copyright © 2016 Robe Lighting s.r.o. - All rights reserved
 All Specifications subject to change without notice