

---

# THE ACOUSTIC SCREEN

---

The Acoustic Screen is designed to deflect sound waves away from the player immediately in front of it, while providing maximum visibility for the player behind. The stand benefits from a strong and stable design and nests for compact storage.

The heavy-gauge steel stem is very strong and rigid. This stand doesn't sway, and yet can be adjusted smoothly and easily to desired height, where it stays automatically. The stem is coated in tough, scratch-resistant epoxy.

The base is made from tubular steel for strength and rigidity without excess weight. Rubber feet preserve your floor and prevent clatter if the stand is knocked. The base is coated in black nylon for ultimate durability.

A cloth cover is available to protect the transparent baffle when the screen is not in use. Screens nest for compact storage.



**RAT**stands

# THE ACOUSTIC SCREEN

Detailed specification

# RATstands

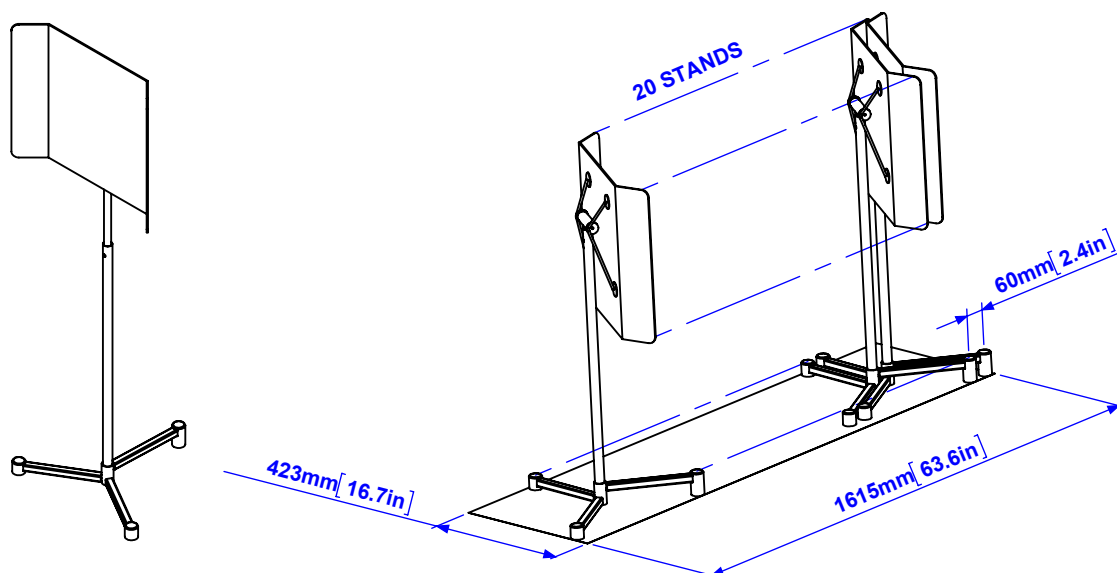
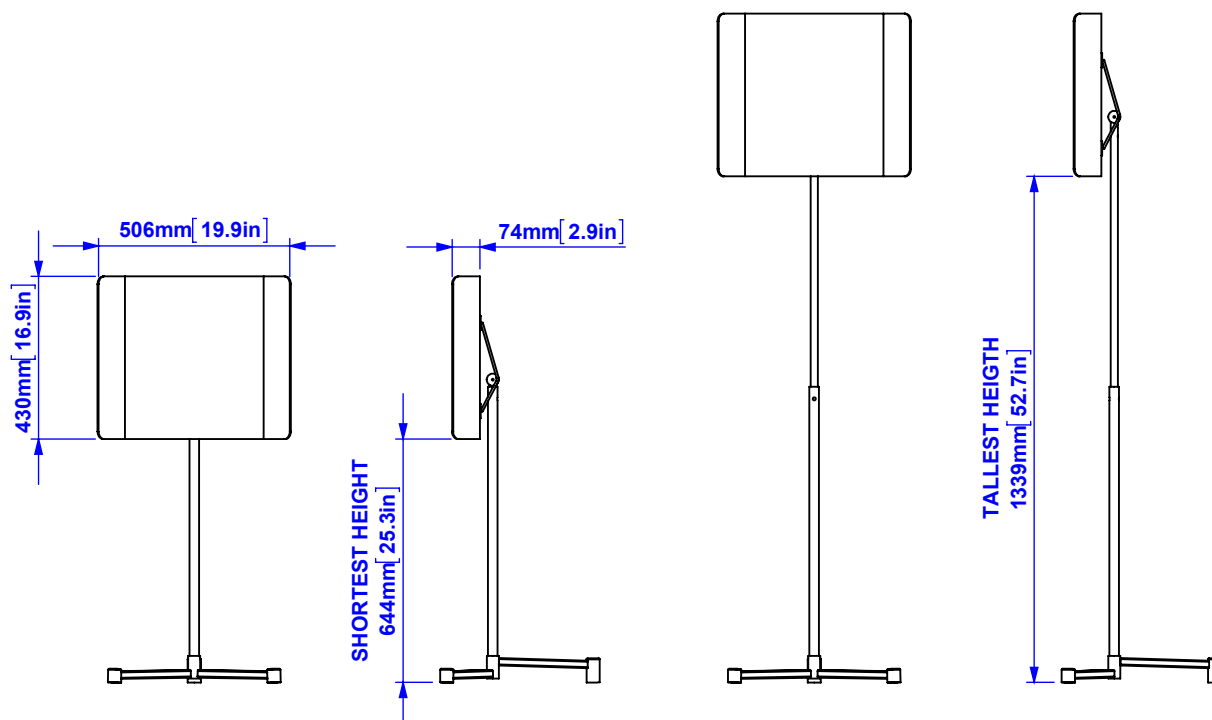

## Specifier's description

A transparent acoustic baffle on a tripod base. Screens can be nested on a flat floor, without requiring a trolley. Rubber feet on base provide 3 point contact with the floor. Provision to adjust the angle and height of the screen. Screen constructed in clear PET.

Construction	
Structural parts	Steel
Feet	Natural rubber
Tray	PET
Coating	Black nylon & black powder coat

Dimensions	
Baffle size	510 x 430mm [20.0 x 17.in]
Height of baffle measured to its mid point	850-1550mm [33.5-61.0in]
Weight of stand without lamp	3.9kg [8.9lb]

General	
Warranty	5 years
Applicable standards	
Part number	65Q1