



# PRO LYFT

## AETOS Range

 **PROLYTE  
GROUP**

### INTRODUCING THE PROLYFT AETOS RANGE

When Simplicity in Motion is the ultimate goal, there's always a next level to meet. ProLyft invites you to take that level further with a product range that is fit to meet the future

#### Get Ready for the Next Level

ProLyft AETOS is the brand new ProLyft hoist range. The AETOS range is fully equipped to meet future demands in lifting equipment and offers clever features and carefully engineered product attributes. The AETOS range comprises of a standard 500kg and 1000kg hoist and will be expanded in the near future.

#### The Unique ProLyft Program

ProLyft sustains a unique service programme on its complete hoist range, developed to offer maximum service and support for all hoist owners.

This program encompasses:

- Installed network of trained and certified Service Points
- Lifetime warranty
- Individual identification - easy web-enabled track and trace functions
- ProLyft Service database – automatic reminders for re-certification
- Test certificates worldwide available for owners of every hoist

#### Standard Features of the AETOS Range:

- Available in a 500kg and a 1000kg hoist body
- Fixed speed of 4m/min
- Red CEE form plug 16Amp 4pin and cable with strain relief for power connection
- Yellow CEE form plug 16Amp 4pin and cable with strain relief for low voltage control (optional)
- Equipped with limit switches on all hoists
- End limit switches are activated by chain stop for 100% repeatable accuracy and easy of use
- External limit switches can be used for hoists used above a grid or false ceiling
- Multiple voltage motor
- Chain bags for 30mtr up to 80mtr available
- 5-pocket load wheel
- Zinc-plated load chain
- 100% sealed aluminium transmission house without oil plugs
- Standard swivel hook on hoist body and hoist chain
- IP 55 protection

#### Easily Adaptable:

- Covers 180 degree rotatable for motor-up use
- Easy mounting of optional second brake
- Brake shaft and electronics prepared for second brake
- Output shaft prepared for rotary limit switch or encoder connection
- All hoists can be double reeved
- Swivelling chain bag bracket for motor-down and motor-up use
- Multiple voltage motor





# PROLYFT

# AETOS Range

## PROLYTE GROUP

### INTRODUCING THE PROLYFT AETOS RANGE

#### Easy to Service:

- Easy replaceable disentangle plate insert
- Easy access to chain guide and load wheel
- Easy mounting of optional second brake
- Easy replacement of electronic circuit board
- Covers equipped with safety steel and captive bolts
- All electronic components integrated on 1 circuit board
- Adjustable clutch

#### Optimised Chain Feeding:

- Specially designed disentangle plate for optimal and jam free chain feeding
- Jam-free steel chain guide
- Disentangle plate insert softer than the chain
- Chain bag bracket with integrated dead end of chain attachment

#### Prepared for D8+, Category A and BGV-C1 use:

- The clutch overload protection device is mounted outside the drive train
- Easy mounting of the second brake
- Proper load capacity marking supplied with second brake
- Limit switches available in direct control and low voltage control versions
- Prepared for double end limit switches
- Output shaft for rotary limit switch or encoder connection

#### Design:

- Damage reducing housing design
- Hand grips integrated in covers
- Replaceable smooth bumpers on covers
- Self coloured plastic covers

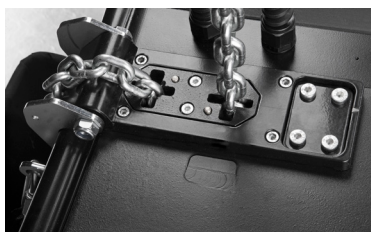

### AETOS 500 KG HOIST

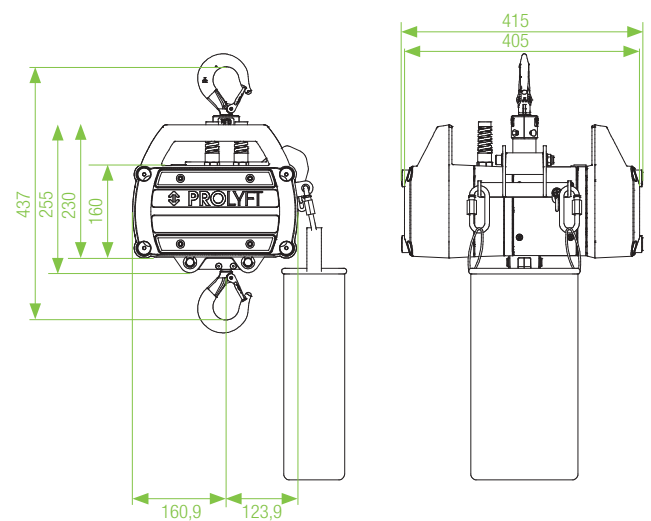

### AETOS 1000 KG HOIST

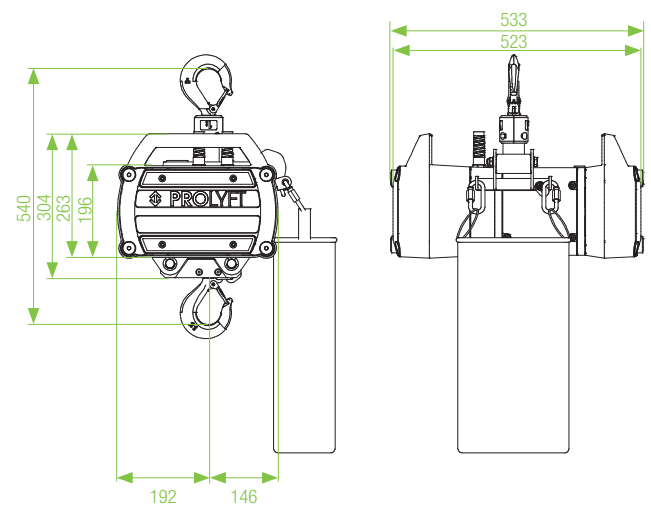

Prolyte Group HQ  
Leek, Netherlands  
info@prolyte.com

Prolyte Products UK Ltd  
Wakefield, England  
info@prolyte.co.uk

Prolyte Products GmbH  
Emsdetten, Germany  
info@prolyte.eu

Prolyte Products RO SRL  
Slatina, Romania  
info@prolyte.ro