

100V 115/120V



## GENERAL INFORMATION

ColorSource Spot Pearl is a variable white-light LED array that utilizes a mix of two different white LEDs that enable a user to set the color temperature anywhere between 2700 K and 6500 K.

The Pearl array includes the same great feature set and high quality construction as their full color siblings including an impressively bright output and simple user interface.

Designed for installations that depend heavily on white light such as studios, houses of worship, and architectural installations, this array features flicker-free operation and an impressively smooth dimming curve.

### APPLICATIONS

- Houses of worship
- Universities and schools
- Studios
- Hospitality
- Retail
- Exhibition centers
- Meeting rooms
- Clubs

### PRODUCT FEATURES

- Variable white light using 2700 K and 6500 K LEDs
- Simple user interface with seven-segment display
- powerCON in and thru
- DMX/RDM in and thru (5-pin XLR or RJ45)
- Optically calibrated
- Tour-ready, aluminum housing

## ORDERING INFORMATION

### ColorSource Spot Pearl Light Engine with Shutter Barrel

(For use with fixed-field lens tubes only)

MODEL	DESCRIPTION
CSSPOTPRLS	ColorSource Spot Pearl with shutter barrel, black
CSSPOTPRL45S	ColorSource Spot Pearl RJ45 with shutter barrel, black

### ColorSource Spot Pearl Light Engine Body

(For use with zoom lens tubes and adapters and for retrofit of existing fixtures)

MODEL	DESCRIPTION
CSSPOTPRL	ColorSource Spot Pearl, body only, black
CSSPOTPRL45	ColorSource Spot Pearl RJ45, body only, black

Color options: -1 = white, -5 = silver gray/custom colors

Fixture ships with a soft-focus diffuser in a gobo holder and a 1.5m powerCON™ power-input cable with a connector of choice. See page 7 for connector options.

**Please note: Lens tubes to be ordered separately.**



## PRODUCT SPECIFICATIONS

## Source

LED details	60 Lumileds LUXEON® C LEDs
Max lumens	9,235
Lumens per watt	46
L70 rating (hours to 70% output)	36,000 hours (estimate pending testing data)

## Color

Colors used	Warm white, cool white
Color temperature range	2700 K - 6500 K
Calibrated array	Yes
Red shift	No

## Optical

Beam angle range	Swappable lens tubes between 5-90 degrees
Gate size	79.24mm
Aperture size	6.25"-14" (depending on lens tube)
Pattern projection	Yes
Pattern size	A or B
Camera flicker control/Hz range	1,200Hz (default) and 25,000Hz (via RDM)

## Control

Input method	DMX-512 via 5-pin XLR or RJ45 connector
Protocols	DMX, RDM
Modes (footprint)	Variable color temperature: ICt (2) Direct: IWCS (4) 1 channel: I (1)
RDM configuration	Yes
UI type	7-segment address display
Local control	Yes
Onboard presets	Yes (12)
Onboard sequences	No
Onboard effects	No
Fixture to fixture control	Yes
Notes	Local level control via UI

## Electrical

Voltage range	100V - 240VAC, 50/60Hz
Input method	powerCON in and thru
Inrush	28A (first half-cycle) at 120V
Fixtures per circuit	7 (20A switched circuit, R20 module or similar)
Wattage (typical/standby)	199W / 1.87W at 120V
Current draw	1.67A at 120V

## Thermal

Ambient operating temp	0-40° C (32-104° F)
Fan (controllable)	No (N/A)
Droop compensation	Yes
dB range	21.2dBa average at 1m
BTUs/hour	679

## Physical

Materials	Die-cast aluminum and plastic
Color options	Black, white, silver or custom color
Mounting options	Yoke and floor
IP rating	IP-20
Weight	17lb (7.7kg) with barrel
Included accessories	Hanging yoke, 1.5m power cable, soft-focus diffuser in gobo holder, gel frame
Notes	See accessories list for power cable options

## Warranty

Full Fixture	5 years
LED Array	10 years

PRODUCT FEATURES



Compatible with Fresnel and CYC adapters

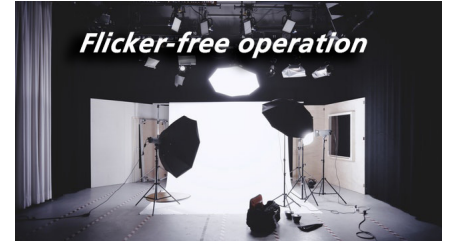

**VERSITILE**

ColorSource Spot Pearl can also be used with the Fresnel and CYC adapters to use throughout your venue

**WARM TO COOL**

Bright white light from 2700 K to 6500 K

**GREAT FOR STUDIOS**

With refresh rates up to 25,000Hz, there is no need to worry about flicker on camera

COLOR METRIC INFORMATION

TM-30-15 3200K - COLORSOURCE SPOT PEARL

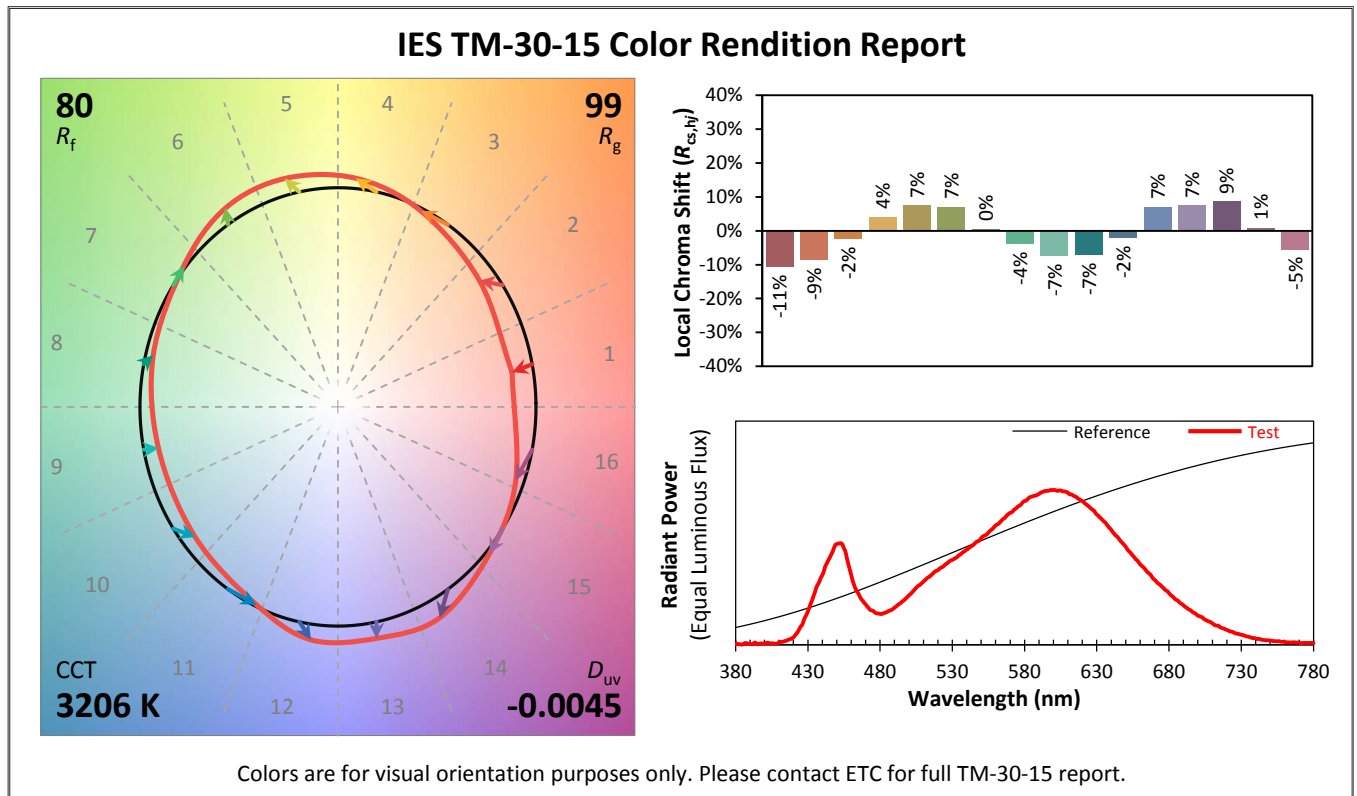

COLOR METRIC INFORMATION

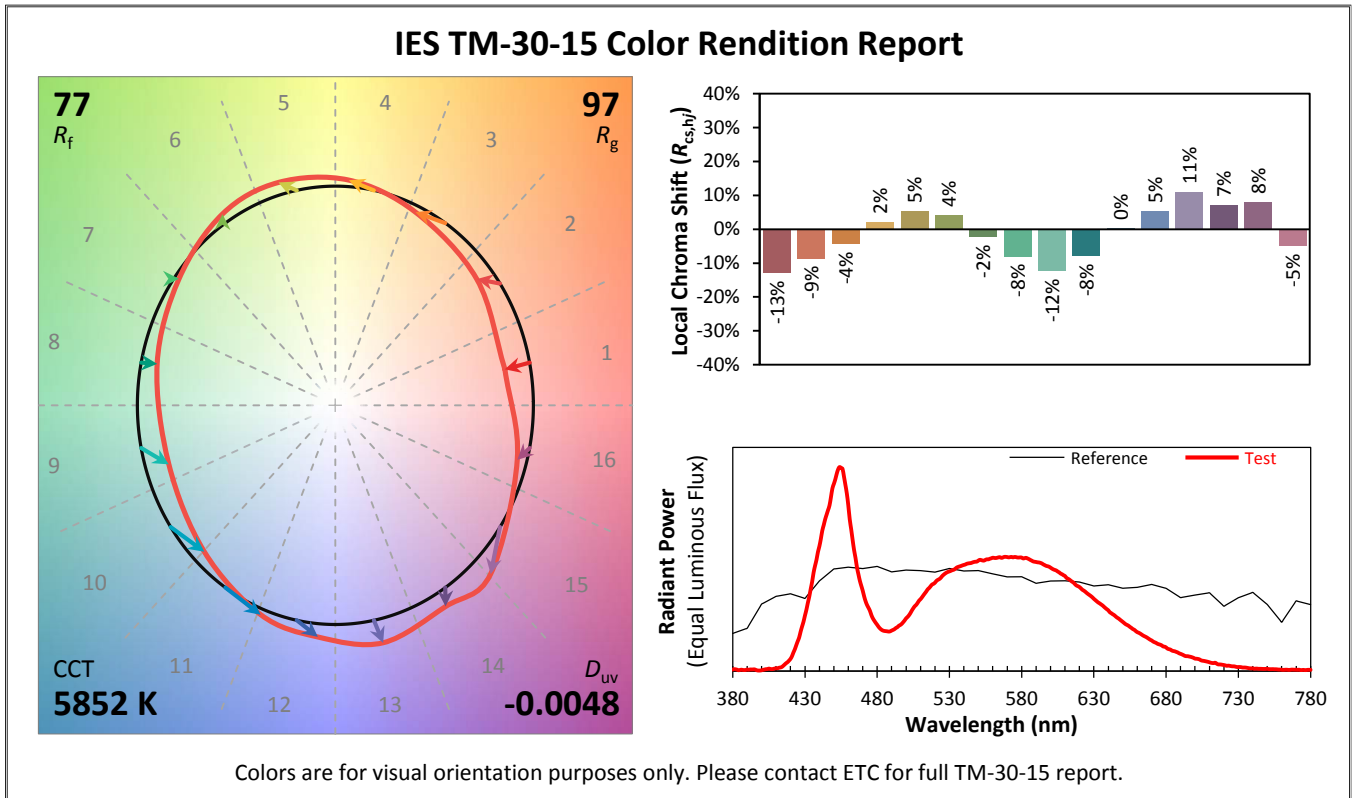

Additional Color Metrics

	CS SPOT 3200K	CS SPOT 5600K
CRI $R_a$ ( $R_g$ )	82 (14)	82 (15)
TLCI	66	62

PHOTOMETRY

See ColorSource Spot Photometry Guide available at [www.etcconnect.com](http://www.etcconnect.com)

## ADDITIONAL ORDERING INFORMATION

### Power Input Cables

Use information below to order 5' power input leads with factory-fitted connectors

MODEL	DESCRIPTION
DPA-A	5ft powerCON to parallel blade U-ground (Edison) connector
DPA-B	5ft powerCON to 20A two-pin and ground (stage pin) connector
DPA-C	5ft powerCON to grounded 20A twistlock connector
DPA-X	5ft powerCON to bare-end power input lead

### Power Thru Jumpers

Note: Power thru jumpers connect to fixture's output (thru) connector to provide link to successive fixtures

MODEL	DESCRIPTION
DPJ-5	5ft powerCON-to-powerCON fixture-to-fixture jumper
DPJ-10	10ft powerCON-to-powerCON fixture-to-fixture jumper

### Diffusers

MODEL	DESCRIPTION
S4LED-SFD	Source Four LED - Soft Focus Diffuser (included)
S4LED-SWD6	Source Four LED - Smooth Wash Diffuser for 6.25in gel frame slots
S4LED-SWD7	Source Four LED - Smooth Wash Diffuser for 7.5in gel frame slots
S4LED-SWD12	Source Four LED - Smooth Wash Diffuser for 10° lens tubes
S4LED-SWD14	Source Four LED - Smooth Wash Diffuser for 5° lens tubes

The Soft Focus Diffuser fits into a standard A-size pattern holder and delivers beautiful, homogenized light when not in sharp focus. Also, use with patterns for dappled and soft-edge projections.

The Smooth Wash Diffuser is used when extra-smooth blending of multiple ColorSource Spot Pearl luminaires is required. The smooth wash diffuser is placed into the gel-frame slot of the lens tube.

### RJ45 to XLR Adapter Cables

MODEL	DESCRIPTION
W6538	RJ45 to female five-pin XLR adapter (6ft)
W6539	RJ45 to male five-pin XLR adapter (6ft)

## CONTROL

### DMX Input Channel Profiles

DMX Channel	ct (Variable color temperature)	dir (Direct)	1ch (One channel)
1	Intensity	Intensity	Intensity
2	Color temperature	Warm white	
3		Cool white	
4		Strobe*	

\*Use DMX values of 0 or 255 for no strobe. Use values of 1-254 to increase the strobe rate from 1 per second up to 33 per second.

**PREFERRED LENSING OPTIONS**

(Lenses sold separately)

**Fixed Beam Lenses**

MODEL	DESCRIPTION
LED50LT	LED-specific 50° EDLT with lenses installed
LED50LT-1	LED-specific 50° EDLT (white) with lenses installed
436EDLT	36° EDLT w/lens installed
436EDLT-1	36° EDLT (white) w/lens installed
426EDLT	26° EDLT w/lens installed
426EDLT-1	26° EDLT (white) w/lens installed
419EDLT	19° EDLT w/lens installed
419EDLT-1	19° EDLT (white) w/lens installed
490LT	90° w/lens installed
490LT-1	90° (white) w/lens installed
470LT	70° w/lens installed
470LT-1	70° (white) w/lens installed
414LT	14° w/lens installed
414LT-1	14° (white) w/lens installed
410LT	10° w/lens installed
410LT-1	10° (white) w/lens installed
405LT	5° w/lens installed
405LT-1	5° (white) w/lens installed

**Zoom Lens Assemblies**

Use with light-engine body models.

MODEL	DESCRIPTION
41530LT	Source Four 15-30° Zoom lens assembly
42550LT	Source Four 25-50° Zoom lens assembly

**LED Adapters**

MODEL	DESCRIPTION
S4LEDCYC	Source Four LED CYC
S4LEDFRES	Source Four LED Fresnel

**Power Consumption with all LEDs at full**

MODEL	VOLTAGE (V)	CURRENT (A)	MAX POWER (W)
CS Spot Pearl	100	2.04	203
	120	1.67	199
	230	0.87	194

**ADDITIONAL ORDERING INFORMATION****Fixture Accessories**

MODEL	DESCRIPTION
400CC	C-Clamp (included)
400SC	Safety Cable
400PH-A	Pattern holder (A size)
400PH-B	Pattern holder (B size)
400PH-G	Glass pattern holder
400RS	Drop-In Iris
400CF	Color frame (6.25")
407CF	7.5in square color frame
400DN	Donut
400TH	Top Hat
400HH	Half Hat
DPSJ-X	25ft powerCON to Edison input power cable with inline switch

**NOTES ABOUT LED LUMINAIRES**

All LED sources experience some lessening of light output and some color shift over time. LED output will vary with thermal conditions. Based on the LED manufacturer's B50 L70 specification, a ColorSource Spot Pearl luminaire will achieve ~70% of its initial output after 36,000 hours of typical usage. In individual situations, LEDs will be used for different durations and at different levels. This can eventually lead to minor alterations in color performance, necessitating slight adjustments to presets, cues or programs.

PHYSICAL

ColorSource Spot Pearl Weights

	WEIGHT*		SHIPPING WEIGHT	
	lb	kg	lb	kg
With Barrel	17.0	7.7	22.0	10.0
Without Barrel	13.0	5.9	16.3	7.4

\* Does not include mounting hardware or lens tube

ColorSource Spot Pearl Dimensions

	HEIGHT		WIDTH		DEPTH	
	in	mm	in	mm	in	mm
ColorSource Spot Pearl	23.33	593	13.36	339	26.44	672

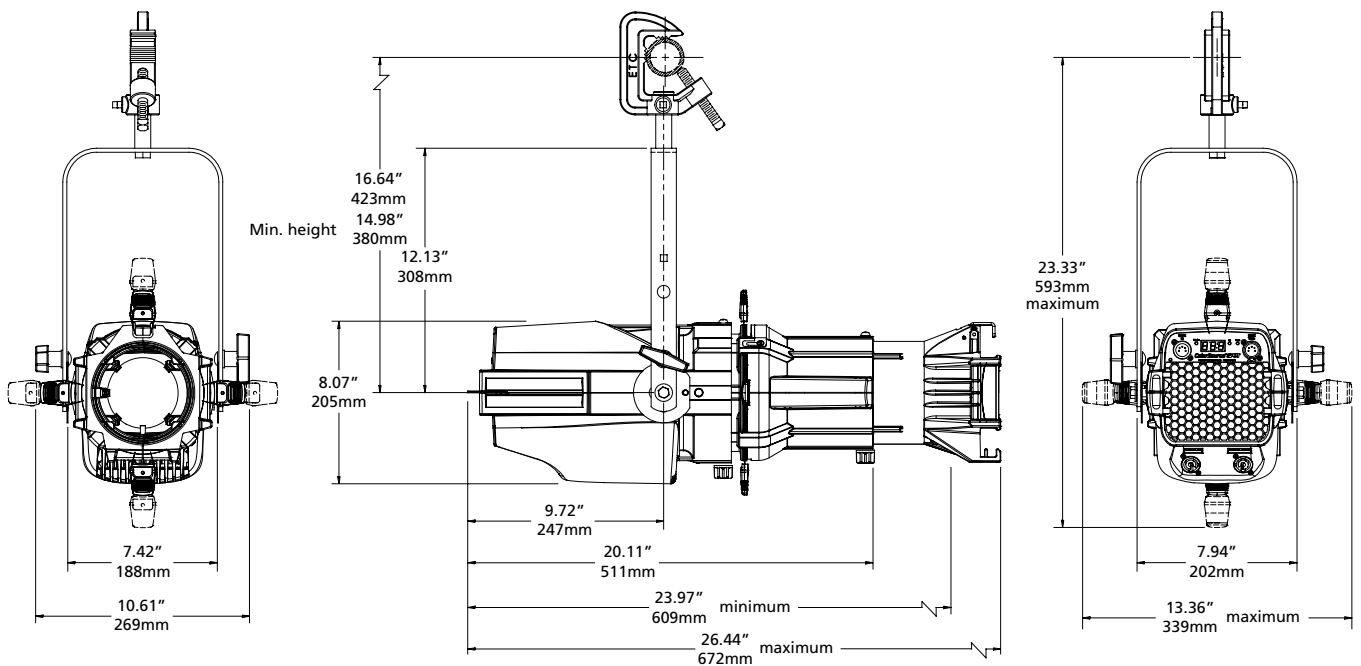

Corporate Headquarters • 3031 Pleasant View Rd, PO Box 620979, Middleton WI 53562 0979 USA • +1 608 831 4116

London, UK • Unit 26-28, Victoria Industrial Estate, Victoria Road, London W3 6UU, UK • +44 (0) 20 8896 1000

Rome, IT • Via Bruno Pontecorvo 10, 00012 Guidonia Montecelio, Roma, Italy • +39 06 32 111 683

Holzkirchen, DE • Ohmstrasse 3, 83607 Holzkirchen, Germany • +49 (80 24) 47 00-0

Hong Kong • Room 1801, 18/F, Tower 1 Phase 1, Enterprise Square, 9 Sheung Yuet Road, Kowloon Bay, Kowloon, Hong Kong • +852 2799 1220

Web • etconnect.com • Copyright©2018 ETC. All Rights Reserved. All product information and specifications subject to change. 7413L1004 Rev A 05/18