



User Manual

www.doughty-engineering.co.uk

Studio Rail

Size 60

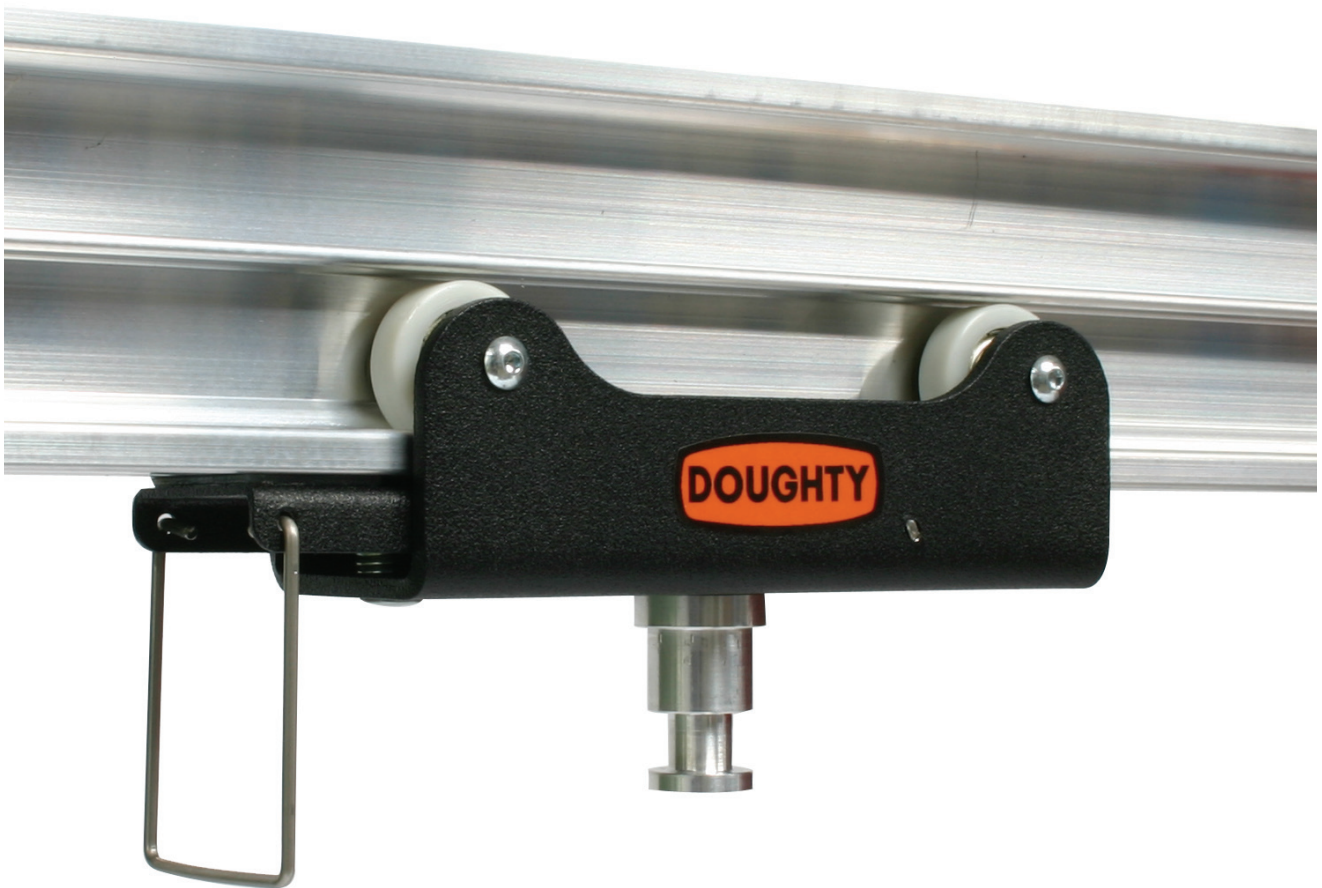

Contents:

Introduction.....	2
Exclusion of Liability	2
Safety Instructions	2
Operating Data	3 - 8
1. Selecting the correct carriage.....	3 - 5
2. Mounting carriages on Studio Rail.....	5
3. Moving carriages on Studio Rail.....	6
4. Fitting equipment to different carriages	7
5. Using Double Swivel Carriages	8
Maintenance	9
Repairs	9
Contact Details	9
EC Declaration of Conformity	10

Introduction

Studio Rail is an extruded aluminium rail system equipped with sliding carriages. The carriages are designed to support a variety of fittings, typically luminaires and curtains/ drapes. Studio Rail is available in straight lengths from two to six metres and six radius curves.

Exclusion of Liability

Using this product for any other purpose than described in this manual is considered contrary to its designated use and the manufacturer cannot be held liable for any damage resulting from such use.

Safety Instructions

1. Studio Rail has a SWL of 100 Kg per 1500mm suspension points unless arranged otherwise by a qualified person in liaison with Doughty Engineering Ltd.

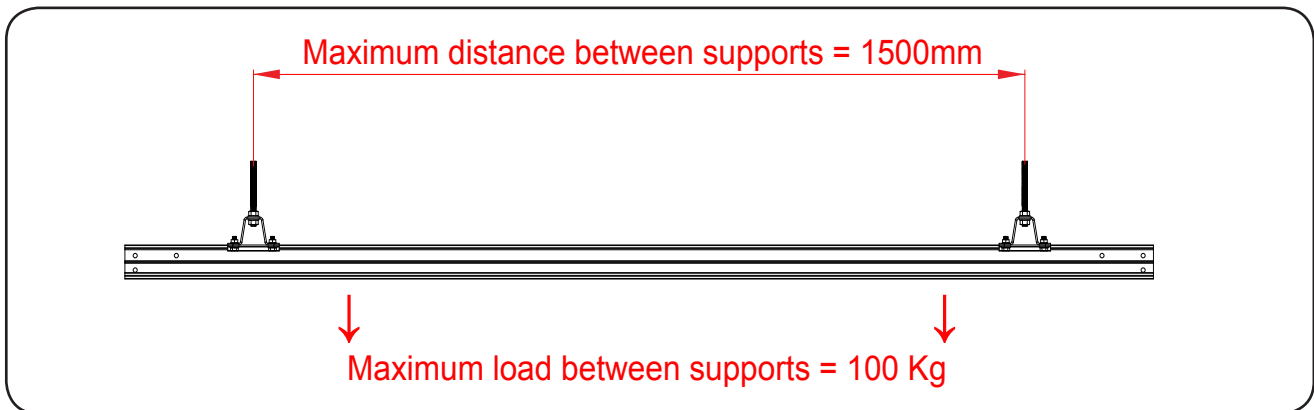

In the event that a customer requests to change the loading specifications, agreement must be reached with Doughty Engineering Ltd to raise an 'Authorised Safe Working Load' Certificate.

2. When using Studio Rail accessories care must be taken not to exceed the SWL of the component or the SWL of the Studio Rail Structure.

3. It is recommended that Safety Bonds are used with this equipment. When Safety Bonds are used responsibility for the following lies with the user:

- i) The Safety Bond is of optimum length, i.e. in the event of failure, the 'drop' distance is kept as short as possible.
- ii) The Safety Bond is attached such that the mounting points are of sufficient strength to withstand the forces imposed by the falling load.

1. Selecting the correct carriages

a. T84220 - Cable Carriage

The cable carriage is designed to support cables used with luminaires etc on the studio rails. The cable carriage is supplied with a Cable Tie Saddle. Fig 1

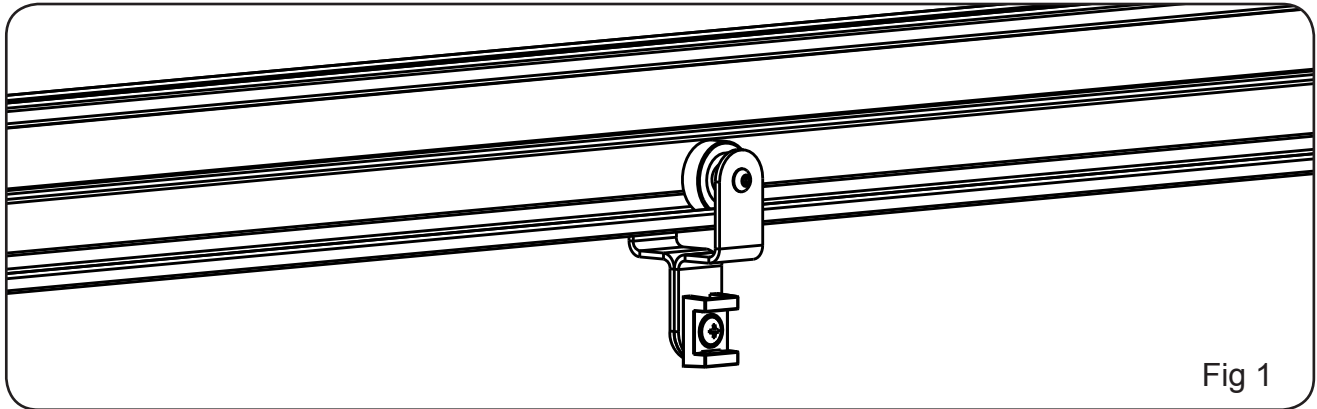

b. T84225 - Curtain Carriage - SWL 6 Kg

Curtain Carriages are used to suspend Curtains/Drapes. This carriage has a SWL of 6 Kg each and is recommended to be used at 300mm intervals. Fig 2

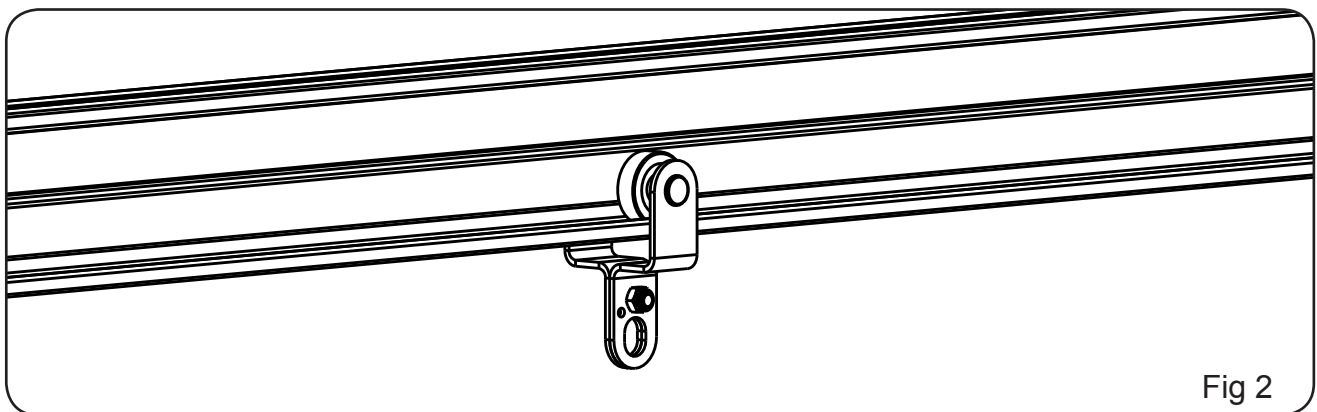

c. T84230 - Cupped Curtain Brake.

The Cupped Curtain Brake is typically used to hold or tension one or both ends of a Curtain/Drape. This brake is fitted with a pole operated cup. Fig 3

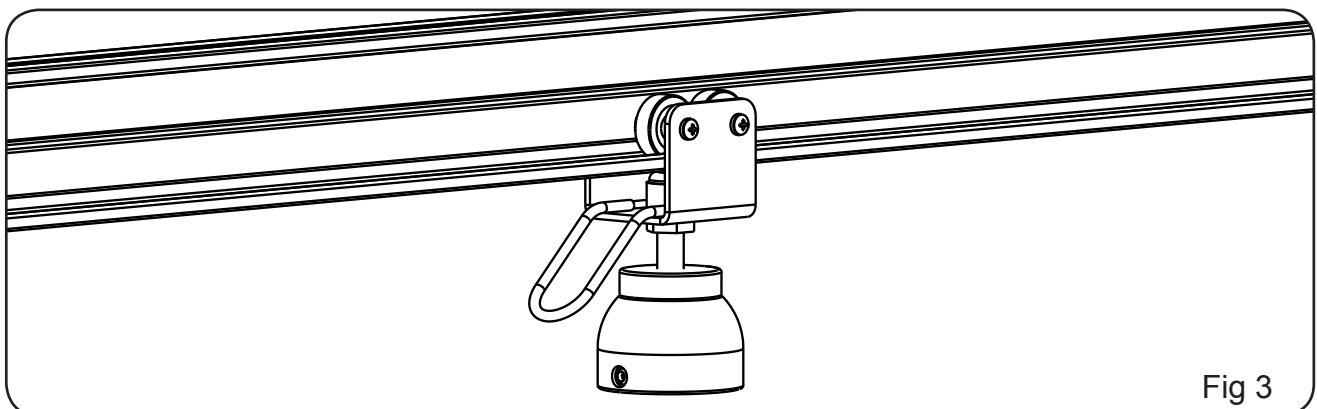

- d. T84185 - 4 Wheel Carriage - 16mm Spigot - SWL 50 Kg
This carriage is typically used to suspend luminaires etc fitted with a 16mm Receiver and is fitted with a friction brake as standard. Fig 4

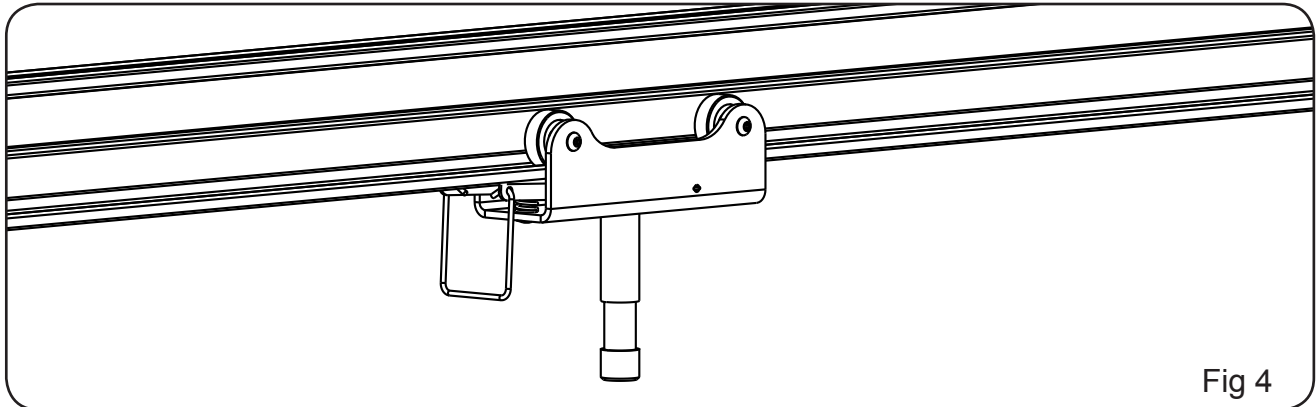

- e. T84185 - 4 Wheel Carriage - 16mm Mini Spigot - SWL 50 Kg
This carriage is typically used to suspend luminaires etc fitted with a 16mm Receiver and is fitted with a friction brake as standard. Fig 5

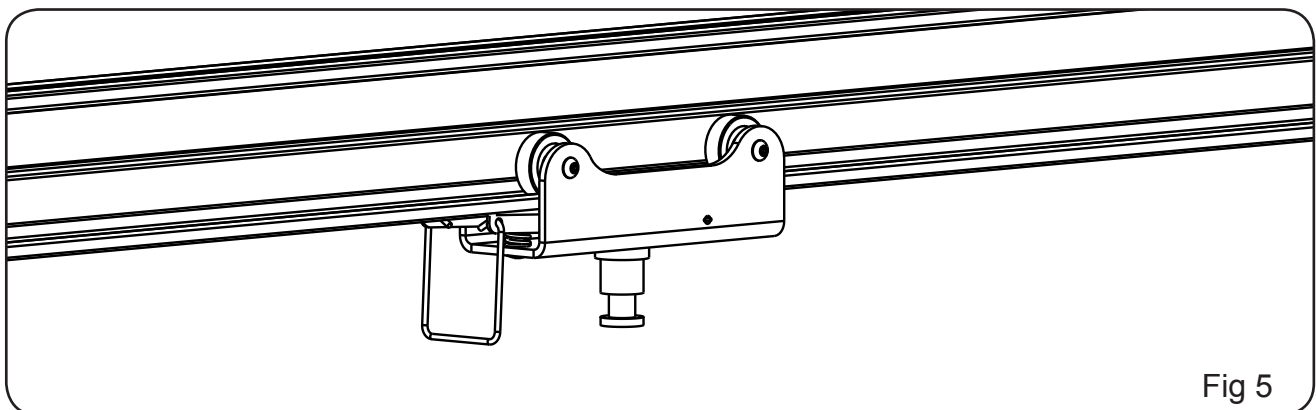

- f. T84205 - 6 Wheel Carriage - 28mm Receiver - SWL 100 Kg
This carriage is typically used to suspend luminaires etc fitted with a 28mm Spigot and is fitted with a friction brake as standard. Fig 6

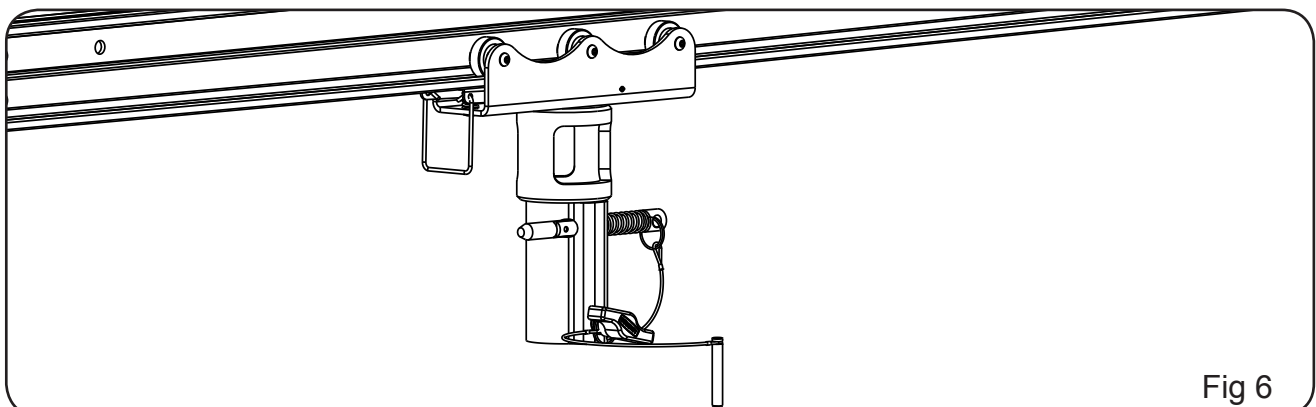

- g. T84215 - 4 Wheel Double Swivel Carriage - SWL 75 Kg
 The Double Swivel Carriage enables two rails to be mounted on top of one another and is ideal for use where two parallel rails are installed with moving rails to suspend the luminaires. Fig 7

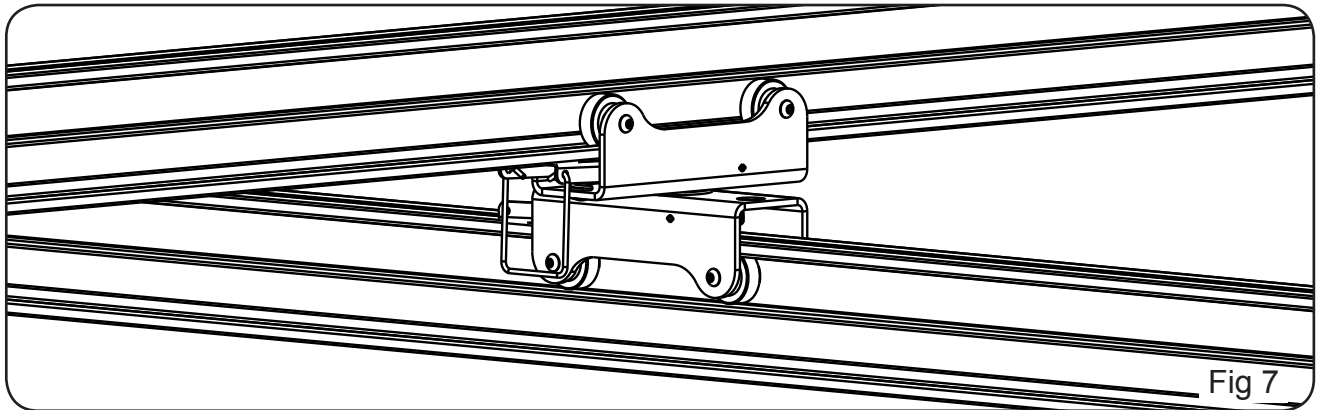

2. Mounting carriages on Studio Rail

Carriages are mounted on Studio Rail by sliding the wheels into the lower section of the rail, as shown. Fig 8

NB: Prior to fitting the carriages, consideration must be given to fitting 'End Stops' on the rails such that the front and rear carriages are prevented from traversing off the end of the rails. Figs 8 & 9

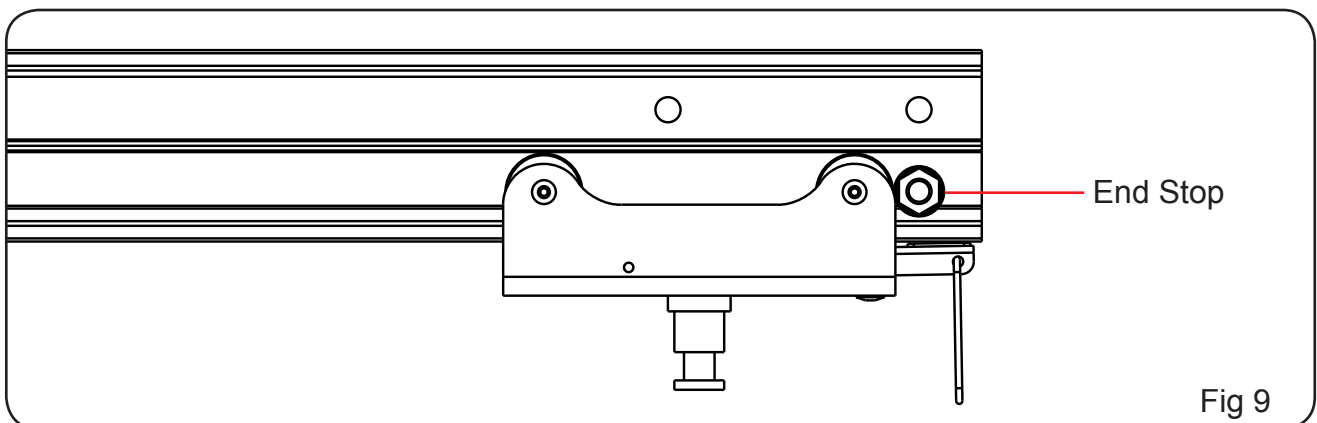
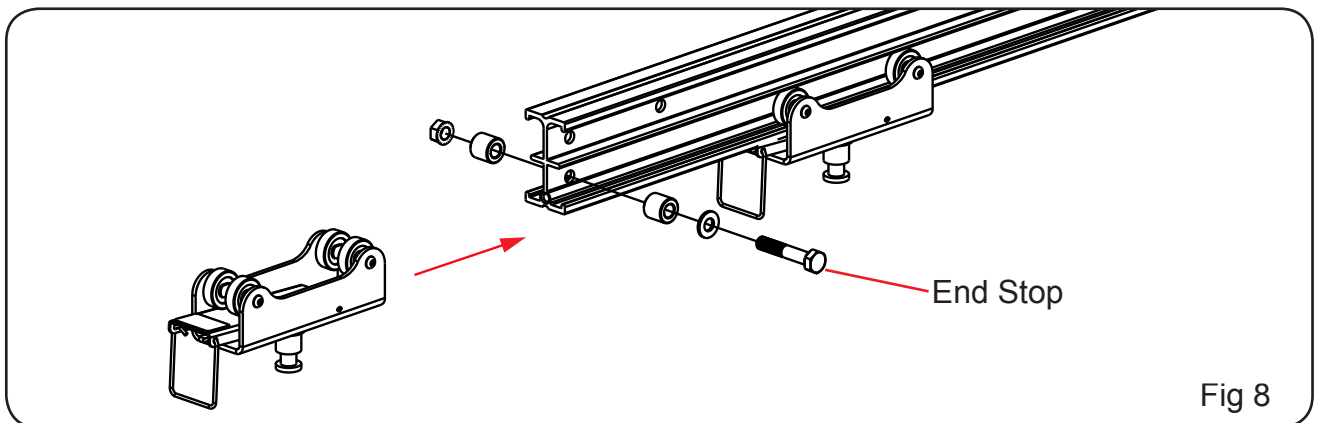

3. Moving the Carriages

Carriages with Friction Brake.

Carriages with a friction brake can be traversed using a operators pole. Carriages can be positioned using the operators pole hook to release the friction brake loop. Final adjustment can be achieved by pushing the carriages. Fig 10
The friction brake serves to prevent the carriages running freely.

Carriages with Pole Cup Brake.

Carriages with a Pole Cup Brake can be moved by turning the Pole Cup to release the brake using an operators pole. The carriages can then be moved into position and the brake reapplied with the operators pole. Fig 11

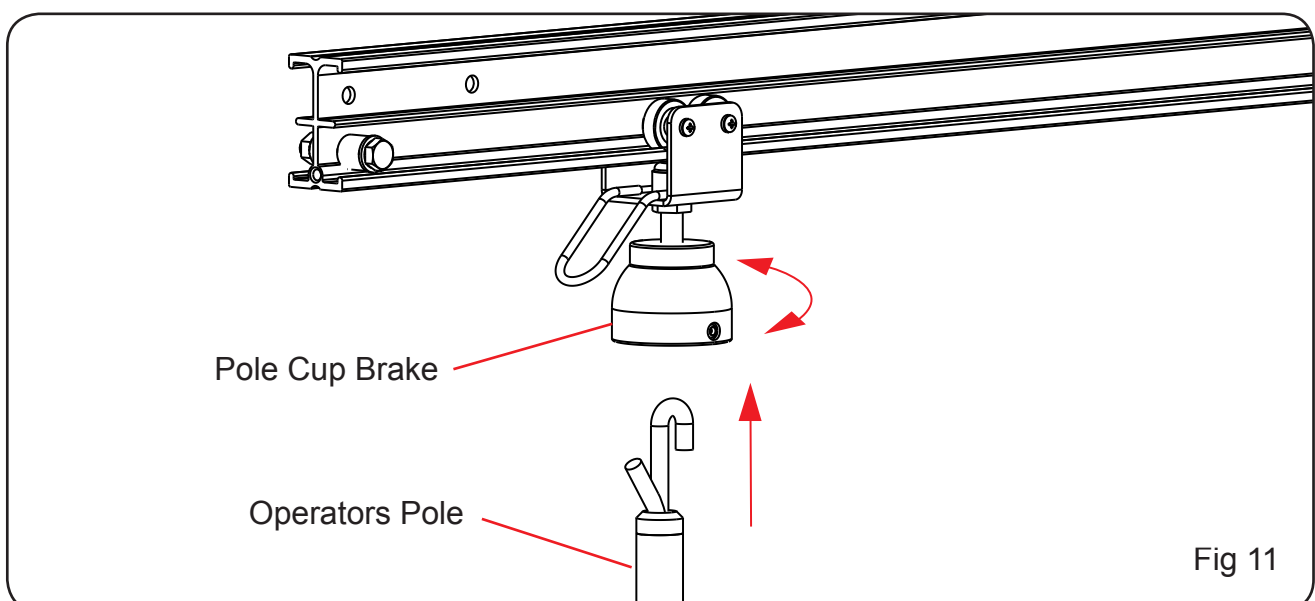
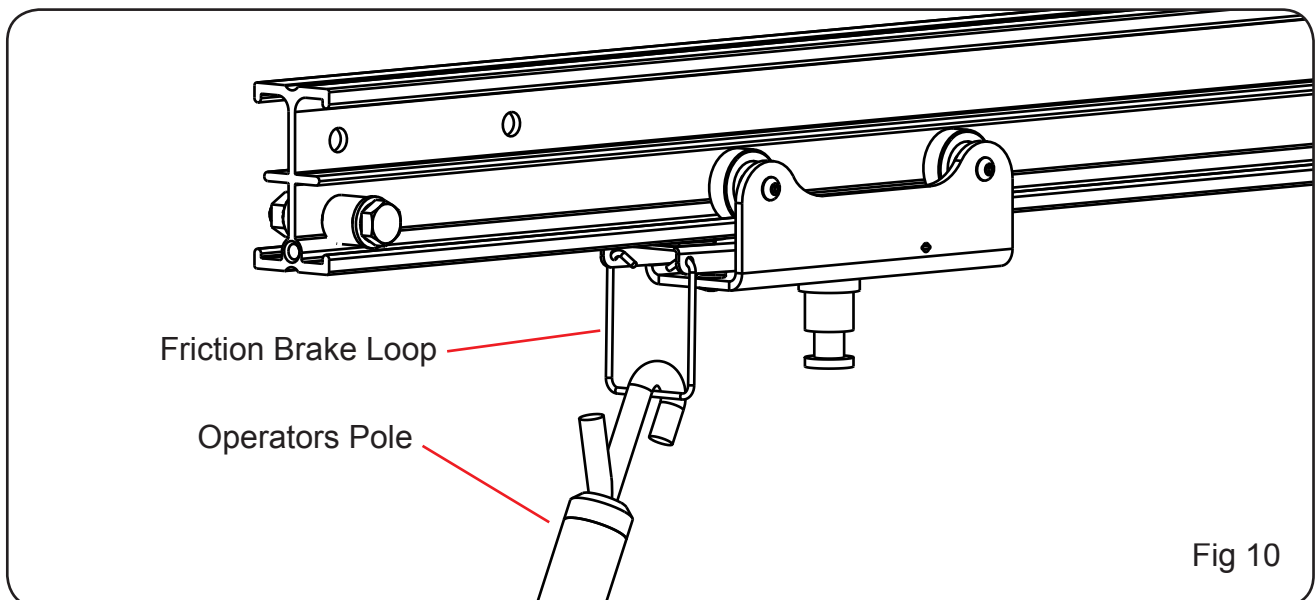

4. Fitting equipment to different carriages

Carriages fitted with a 16mm Spigot are designed to accept equipment fitted with a 16mm Receiver. The Spigot has a machined groove to accommodate the locking screw in the receiver.

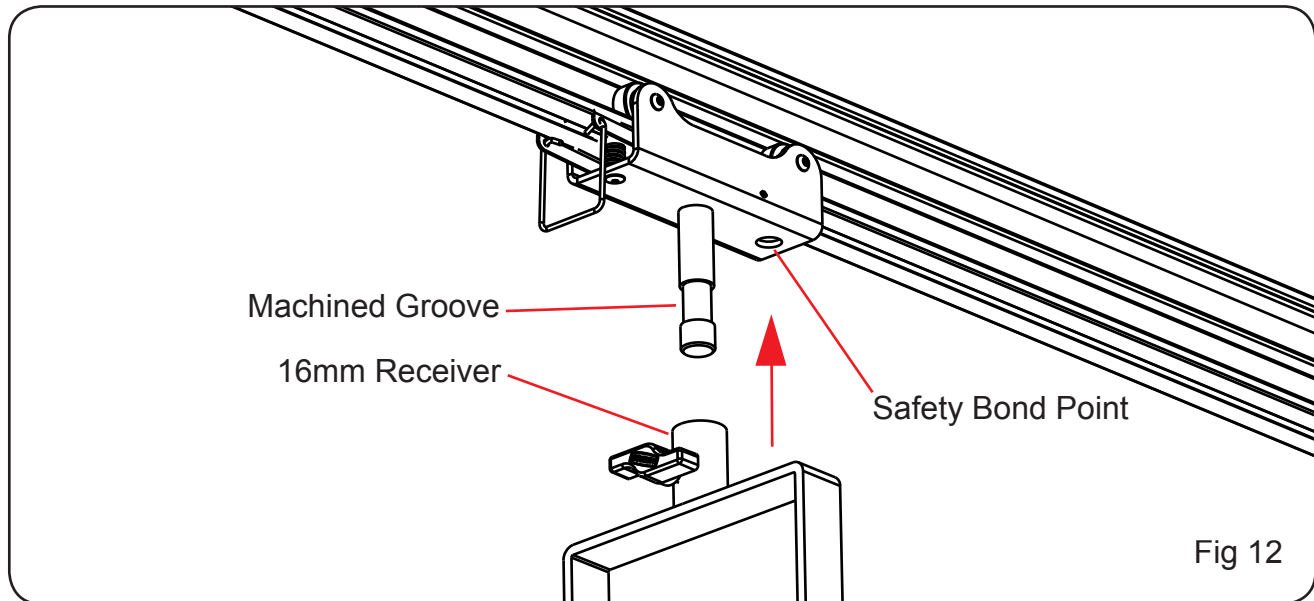

Carriages fitted with a 28mm Spigot are designed to accept equipment fitted with a 28mm Spigot. The receiver has 3 safety points incorporated in its design.

The first point is the safety pin, this pin is designed to take the initial weight of the equipment being suspended. The second point is the sword pin, this pin secures the spigot in the receiver and still allows the spigot to rotate. The third point is the Doughty Knob, this stops the spigot rotating in the receiver.

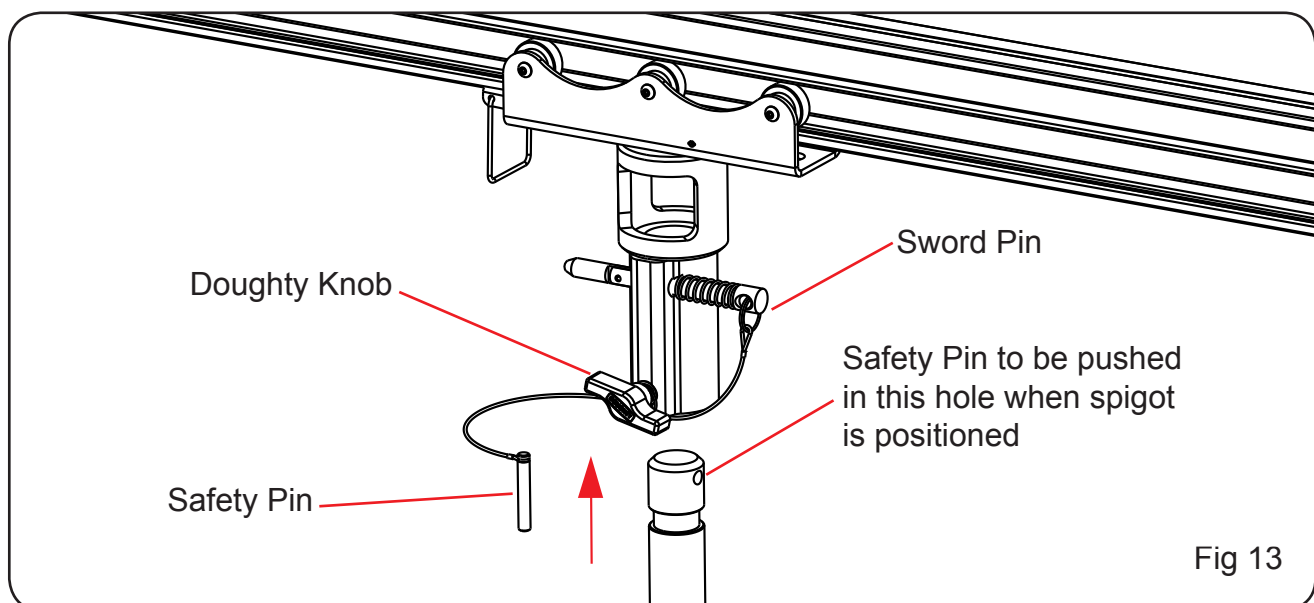

5. Using Double Swivel Carriages

Double swivel carriages are designed to be used in pairs mounting a moving rail to a pair of parallel rails. Fig 14

The moving rail can be positioned using the operators pole hook to release the friction brake loop on the Double Swivel Carriages. Final adjustment can be achieved by pushing the carriages. Fig 15

End stops must be fitted in the upper section of the moving rail to stop the rail sliding through the Double Swivel Carriages and becoming dismounted.

End stops are also fitted to the lower section of the moving rail to stop equipment from traversing off the end of the rails.

The friction brake serves to prevent the carriages running freely.

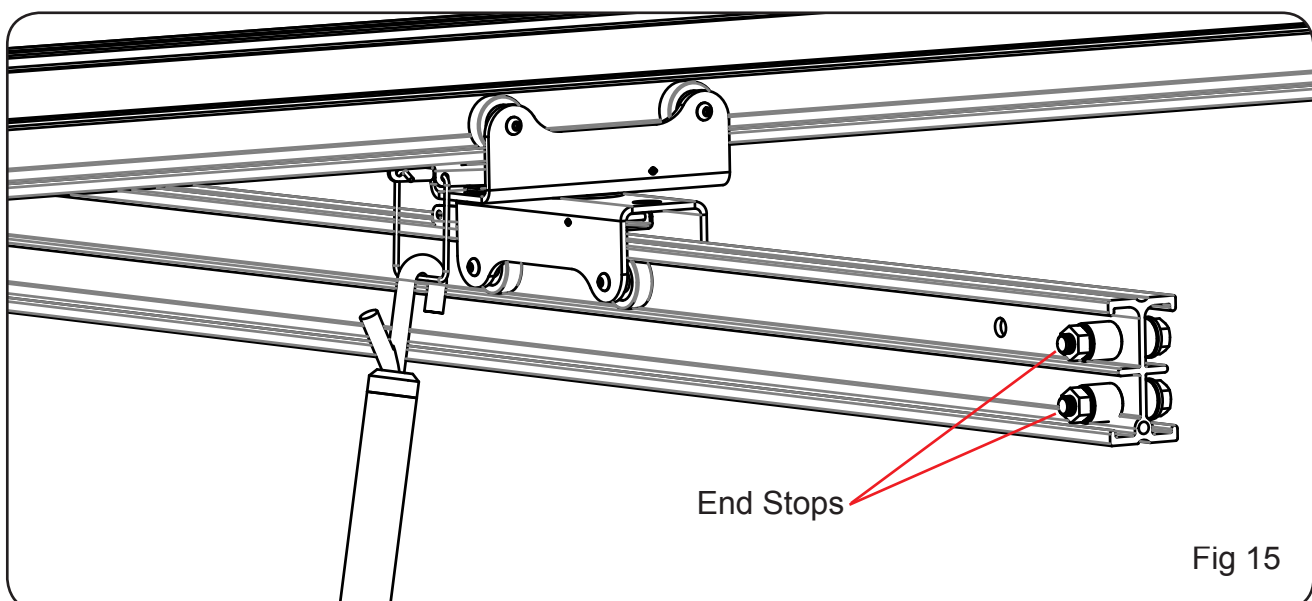
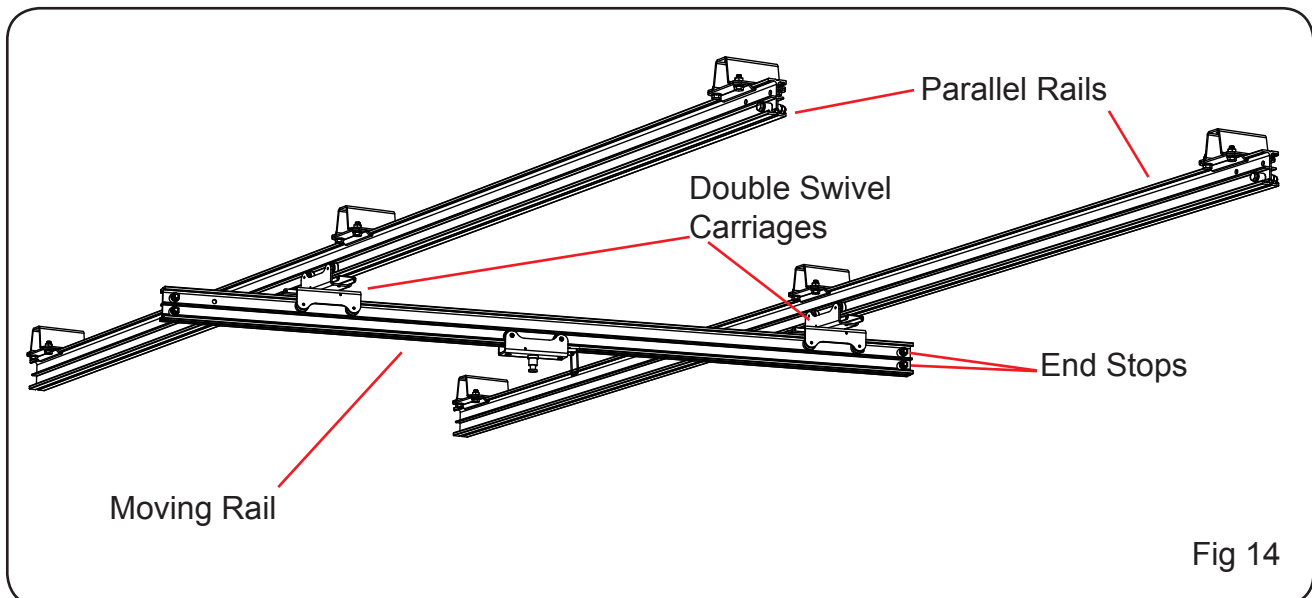

Maintenance

Do not oil or grease any components of rails.

A 100% proof load test must be carried out by a qualified person at the following intervals:

- During initial commissioning
- After each reassembly
- Annually

Testing Tasks include:

- Inspect rail suspension points
- Ensure carriages run freely and brakes are operational
- Check all safety devices are complete and serviceable

Repairs

Repair may only be carried out by competent personnel trained by Doughty Engineering Ltd or an approved service agent as listed on the Doughty Web Site.

Only Doughty replacement parts should be used.

Contact Details



Doughty Engineering Ltd

Crow Arch Lane

Ringwood, Hampshire, BH24 1NZ

Tel: +44 (0) 1425 478961 Fax: +44 (0) 1425 474481

email: sales@doughty-engineering.co.uk

Web: www.doughty-engineering.co.uk

Note: Whilst every effort has been made to ensure that the information contained within this manual is correct, Doughty Engineering does not accept any liability for errors or omissions. Specifications and technical data are intended for guidance purposes only and may vary.



Doughty Engineering Ltd

Doughty Engineering Ltd

Crow Arch Lane, Ringwood, Hampshire, BH24 1NZ

Tel: +44 (0) 1425 478961 Fax: +44 (0) 1425 474481

Web: www.doughty-engineering.co.uk

email: sales@doughty-engineering.co.uk

EC DECLARATION OF CONFORMITY

Doughty Engineering Limited hereby certify that the equipment stated below has been designed to comply with all relevant sections of the specifications referenced below and complies with all applicable Essential Requirements of the EC Directives and amendments and the National Laws and Regulations adopting these Directives.

Description: Studio Rail - Size 60

Is in conformity with the provisions of the following

EC Directives:

Machinery Directive 98/37/EEC

Harmonised Standards:

BS EN 292:Part 1:1991 BS EN 292:Part 2:1991 BS EN ISO 9001:1994
BS EN 755-2

National Technical Standards & Specifications:

BS 7905-1:2001 BS 1615 BS 1474

Signed: *Nigel Curtis* Date: 25-04-08

Name: Nigel Curtis Position: Technical Director

Being the responsible person appointed by the manufacturer.



DEQ 083 Rev 4

Company Registration No. London 972614
Registered Office: Crow Arch Lane, Ringwood, Hants, BH24 1NZ
Directors: M.B. Lister, J.C.G. Chiverton, N.D. Curtis, S.C. Wright