



CLF HERCULES

- 30° BEAM ANGLE
- COMPACT & LIGHT HOUSING
- HIGH LIGHT OUTPUT
- DOUBLE BRACKET FOR FLOOR AND TRUSS MOUNTING
- 'FLICKER FREE' OPERATION
- INTENSE COLOURS DUE TO SPECIALLY SELECTED LEDs
- WIRELESS DMX (OPTIONAL)



HERCULES

RGBW AUV COLOUR MIXING SMART FILTER SYSTEM®



The CLF Hercules is an innovative concept which combines superior RGBWAUV colour mixing, smart design and adaptable beams through the exclusive Smart Filter System. Specially selected high quality LEDs provide deep, saturated colours with an outstanding white balance and the exceptionally smooth projection. Guaranteed flicker free operation makes the Hercules suitable for tv shows, theatre and corporate events. Through the Smart Filter System®, users can adapt the shape and beam angle by inserting specially designed filters. Even elliptical filtersets are available. The unique shape of the Hercules prevents cables to be in sightlines. The fixture has a double bracket so it can be placed on

the floor or mounted to truss structures by using the unique CLF quicklock system. This system is easy to use & time-saving. A clear LCD display gives access to all settings, including different dimmer curves. Controlled by DMX, the Hercules offers extensive colour temperature control & a pre-programmed FX engine. Standard the Hercules comes with 5p XLR connectors witch can be easily swapped to 3p XLR. Available accessories are a detachable snoot, barndoor and a Wireless Solution W-DMX™ receiver. The CLF Hercules is the perfect choice for professional & high demanding users.

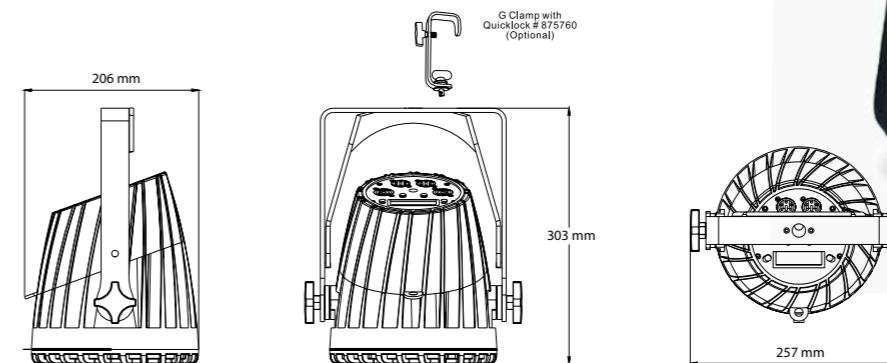

Height	Eavg,Emax	Angle: 29.10°	Diameter
1.219m	3614,5425lx		63.29cm
2m	1343,2016lx		103.82cm
3m	596,9895.9lx		155.73cm
4m	335,7,504.01lx		207.64cm
7.7m	90.60,136.01lx		399.71cm

FACTSHEET

DMX channels	6, 8 or 12 channels
Beam angle	25° (adaptable through Smart Filter System)
Power supply	100 - 240 VAC
Power consumption	Max. 105 Watt
Cooling	Low noise regulated fan
DMX connection	3 & 5p XLR in & out
Dimensions	303 x 257 x 206mm (hxxwx d)
Weight	5,5 Kg
Certification mark	CE
Article number	156170
Included items	Power cable
IP rating	IP22