

L5

The ARRI L-Series is an LED Fresnel fixture so close to its conventional counterpart in function and performance that it creates a previously unattainable opportunity: like-for-like replacement of traditional Fresnels with LED-based units.

Portable. Durable. Tuneable.

The L5 addition to the L-Series perfectly complements the L7, allowing for more mobile lighting and a wider range of power classes for television studios. Its compact size and low weight allows the L5 to be rigged in tight places and hung from low ceilings. The L5 is also ideal for cramped location shoots and interview setups. Low heat allows safer and more comfortable shooting conditions. This versatility and superb light quality makes the L5 a highly anticipated addition to the award-winning L-Series family.

New features available on the L5 include a PowerCON power connector and an on-board battery input that permits industry-standard batteries to power the L5 without any sacrifice in terms of features or light output. The resulting increase in portability opens up whole new application areas, giving productions with the L5 the tremendous freedom to move and work fast.

The L5 is approximately 45% brighter than a 300 watt tungsten Fresnel, but only consumes 115 watts. When compared to the L7, the L5 is half the weight and size. In addition, the L5 maintains all the popular features of its larger sibling, including tuneability from 2,800 K to 10,000 K; green/magenta correction; hue selection; saturation control; and on-board DMX for communication with third-party control products.



L5-C Color temperature, tint and hue can be continuously adjusted from 2,800 K to 10,000 K, between full plus or minus green and RGBW colors.

L5-T Tuneable Tungsten allows for fine-tuning of the tungsten color temperature from 2,600 K to 3,600 K with increased brightness over the L5-C, and is particularly suited to applications requiring precise matching to conventional tungsten lampheads.

L5-D Tuneable Daylight allows for fine-tuning of the daylight color temperature from 5,000 K to 6,500 K with increased brightness over the L5-C, and is particularly suited to applications requiring precise matching to daylight balanced light sources.

2,800 - 10,000 K

2,600 - 3,600 K

5,000 - 6,500 K

approx. 9 % brighter than L5-C

approx. 20 % brighter than L5-C

Order No.	Description
L0.0001958	L5-C, Hanging, Blue/Silver
L0.0001954	L5-C, Hanging, Black
L0.0001953	L5-C, Pole Operated, Blue/Silver
L0.0001952	L5-C, Pole Operated, Black
L0.0001955	L5-C, Stand-Mount, Blue/Silver, 3 m Cable, Schuko Connector
L0.0001956	L5-C, Stand-Mount, Blue/Silver, 7 m Cable, Edison Connector

Order No.	Description
L0.0001982	L5-TT, Hanging, Blue/Silver
L0.0001978	L5-TT, Hanging, Black
L0.0001977	L5-TT, Pole Operated, Blue/Silver
L0.0001976	L5-TT, Pole Operated, Black
L0.0001979	L5-TT, Stand-Mount, Blue/Silver, 3 m Cable, Schuko Connector
L0.0001980	L5-TT, Stand-Mount, Blue/Silver, 7 m Cable, Edison Connector

Order No.	Description
L0.0001992	L5-DT, Hanging, Blue/Silver
L0.0001988	L5-DT, Hanging, Black
L0.0001987	L5-DT, Pole Operated, Blue/Silver
L0.0001986	L5-DT, Pole Operated, Black
L0.0001990	L5-DT, Stand-Mount, Blue/Silver, 3 m Cable, Schuko Connector
L0.0001991	L5-DT, Stand-Mount, Blue/Silver, 7 m Cable, Edison Connector

HANGING versions include the following base configuration: 16 mm / 28 mm Combo Pin (Baby 5/8 inch / Junior 1-1/8 inch Combo Pin), 1.5 m (5 ft) Cable with Bare Ends, Integrated 5-Pin DMX In and Thru;

POLE-OPERATED versions include the following base configuration: Pole Operation for Pan, Tilt and Focus, 16 mm / 28 mm Combo Pin (Baby 5/8 inch / Junior 1-1/8 inch Combo Pin), 1.5 m (5 ft) Cable with Bare Ends, Integrated 5-Pin DMX In and Thru;

STAND-MOUNT versions include the following base configuration: 16 mm / 28 mm Combo Pin (Baby 5/8 inch / Junior 1-1/8 inch Combo Pin), Inline Switch, Integrated 5-Pin DMX In and Thru.

L5 SERIES
CUT. SHAPE. FOCUS. TUNE.

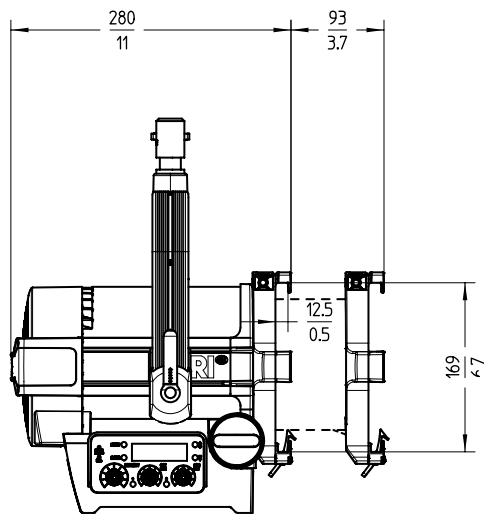
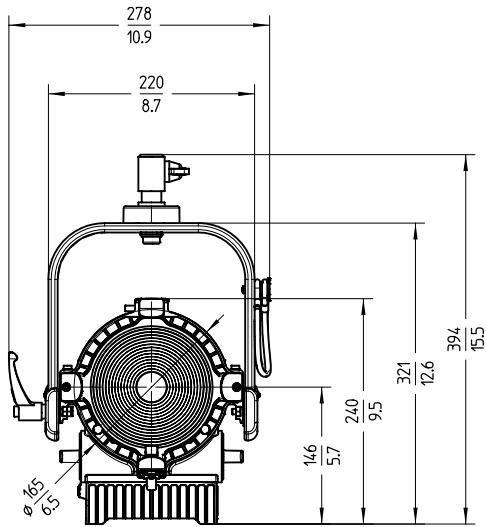

Specifications

Optical System	Focusable Fresnel
Lens Diameter	137 mm / 5 inch
Beam Angle	14° to 50° (Half Peak Angle)
Weight	Manual Version - 5.1 kg (11.2 lbs) Pole Op Version - 7 kg (15.4 lbs)
Handling	Adjustable Sliding Stirrup, High Strength Tilt Lock, Pole Operation Option (Pan, Tilt and Focus)
Mounting	16 mm / 28 mm Combo Pin (Baby 5/8 inch / Junior 1-1/8 inch Combo Pin)
Tilt Angle	+/- 90°
Power Supply Range	90 - 250 V ~, 50 - 60 Hz
Power Consumption	L5-C: 100 W Nominal, 115 W Maximum L5-TT: 100 W Nominal, 110 W Maximum L5-DT: 104 W Nominal, 110 W Maximum
Power Connection	powerCON TRUE1 (Bare Ends / Schuko / Edison Cables Available)
Battery Connector	4-Pin XLR Connector (Pin 1: Negative / Pin 4: Positive)
Battery DC Voltage Range	23 to 36 V =
White Light	L5-C: 2,800 K to 10,000 K Continuously Variable Correlated Color Temperature L5-TT: 2,600 K to 3,600 K Continuously Variable Correlated Color Temperature L5-DT: 5,000 K to 6,500 K Continuously Variable Correlated Color Temperature
Colored Light (L5-C only)	Full RGB+W Color Gamut with Hue and Saturation Control
Color Temperature Tolerance	+/- 100 K (nominal), +/- 1/8 Green-Magenta (nominal)
Color Rendition	L5-C: CRI Average > 94, TLCI Average > 90 L5-TT: CRI Average > 96, TLCI Average > 93 L5-DT: CRI Average > 93, TLCI Average > 90
Green-Magenta Adjustment	Continuously Adjustable (Full Minusgreen to Full Plusgreen)
Dimming	0 to 100% continuous
Control	5-Pin DMX In and Through, On-Board Controller, Mini-USB
Remote Device Management (RDM)	DMX Setup, Hour Counter and Standard RDM Commands
Mini-USB Interface	DMX Setup, Fixture Status and Firmware Upgrade Through PC Software
Housing Color	Blue/Silver, Black
Ambient Temperature Operation	-20 to +45° C (-4 to +113° F)
IP Rating	IP 20
Estimated LED Lifetime (L70)	50,000 hours
Estimated Color Shift Over Lifetime (CCT)	+/- 5%
Certifications	CE, FCC; GS, cNRTLus, CB, PSE

All specifications are nominal / typical values.

Photometric Data (nominal results)

	3 m / 9.8 ft		5 m / 16.4 ft		7 m / 23.0 ft		9 m / 29.5 ft	
L5-C	3,200 K	5,600 K	3,200 K	5,600 K	3,200 K	5,600 K	3,200 K	5,600 K
Spot: 15°	3111 lx / 289 fc	3278 lx / 305 fc	1120 lx / 104 fc	1180 lx / 110 fc	571 lx / 53 fc	602 lx / 56 fc	346 lx / 32 fc	364 lx / 34 fc
Middle: 30°	967 lx / 90 fc	1022 lx / 95 fc	348 lx / 32 fc	368 lx / 34 fc	178 lx / 16 fc	188 lx / 17 fc	107 lx / 10 fc	114 lx / 11 fc
Flood: 50°	380 lx / 35 fc	399 lx / 37 fc	137 lx / 13 fc	144 lx / 13 fc	70 lx / 6 fc	73 lx / 7 fc	42 lx / 4 fc	44 lx / 4 fc
L5-TT	3,200 K		3,200 K		3,200 K		3,200 K	
Spot: 15°	3489 lx / 324 fc		1256 lx / 117 fc		641 lx / 60 fc		388 lx / 36 fc	
Middle: 30°	1056 lx / 98 fc		380 lx / 35 fc		194 lx / 18 fc		117 lx / 11 fc	
Flood: 50°	400 lx / 37 fc		144 lx / 13 fc		73 lx / 7 fc		44 lx / 4 fc	
L5-DT		5,600 K		5,600 K		5,600 K		5,600 K
Spot: 15°		4056 lx / 377 fc		1460 lx / 136 fc		745 lx / 69 fc		451 lx / 42 fc
Middle: 30°		1244 lx / 116 fc		448 lx / 42 fc		229 lx / 21 fc		138 lx / 13 fc
Flood: 50°		493 lx / 46 fc		178 lx / 16 fc		91 lx / 8 fc		55 lx / 5 fc